

Revision Physics Paper 2 – Unit 6 Waves

Waves in air, fluids and solids

- Transverse and longitudinal waves
- Properties of waves
- Reflection of waves (physics only)
- Sound waves (physics only) (HT)
- Waves for detection and exploration (physics only) (HT)

Electromagnetic Waves

- Types of electromagnetic waves
- Properties of electromagnetic waves
- Uses and applications of electromagnetic waves
- Lenses (physics only)
- Visible light (physics only)

Black body radiation (physics only)

- Emission and absorption of infrared radiation
- Perfect black bodies and radiation

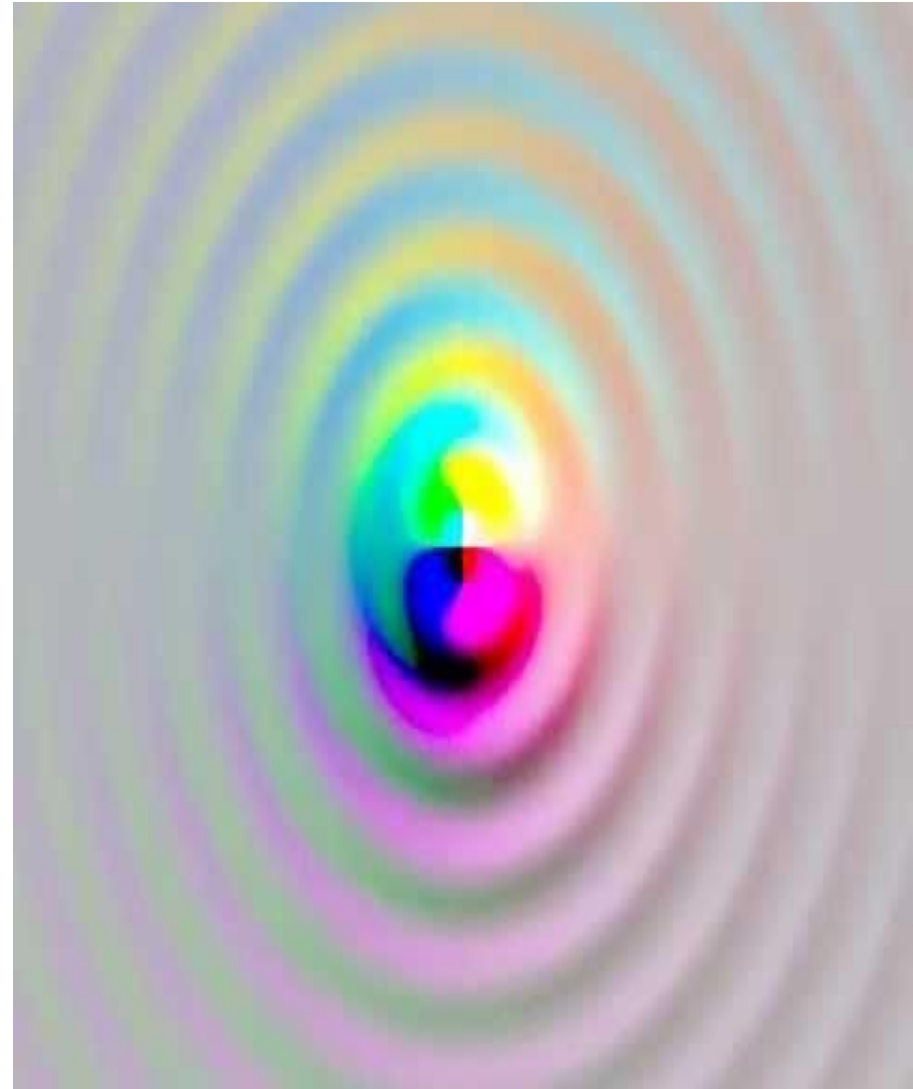

LearnIT! KnowIT!

Waves in air, fluids and solids

- Transverse and longitudinal waves
- Properties of waves
- Reflection of waves (physics only)
- Sound waves (physics only) (HT)
- Waves for detection and exploration (physics only) (HT)



Transverse and Longitudinal Waves

Transverse Wave

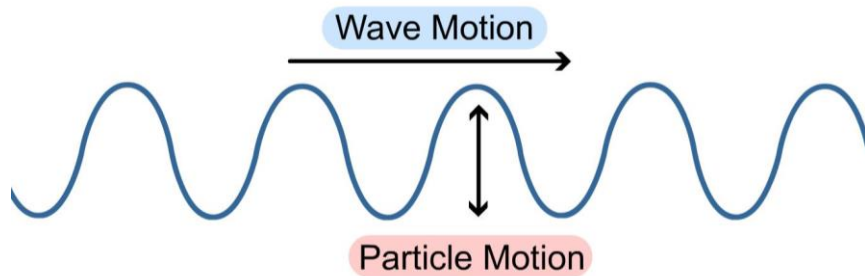

Longitudinal Wave

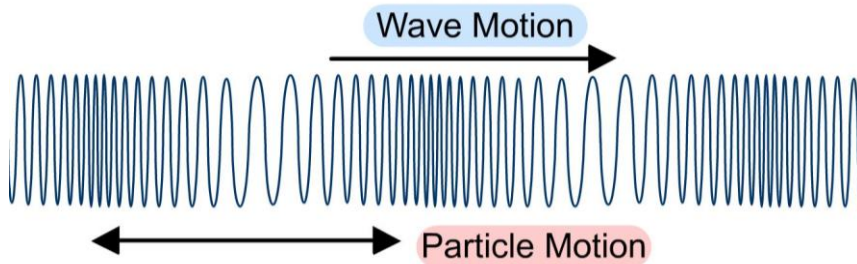

Remember, the particles in a wave move up and down or backwards and forwards only.

It is energy, NOT the particles, that move from one place to another!

In a **transverse wave** the particles within the wave move perpendicular (at 90°) to the direction the wave is travelling.

This is the wave produced in a rope when it is flicked **up and down**.

Examples of transverse waves are: **Water waves, electromagnetic (light) waves and guitar strings.**

Longitudinal waves are compression (squash) waves where the particles are vibrating in the same direction as the wave movement.

This is the wave produced when a spring is **squashed** and released.

Examples of longitudinal waves are: **Sound waves and a type of seismic (P) wave.**

Transverse and Longitudinal Waves

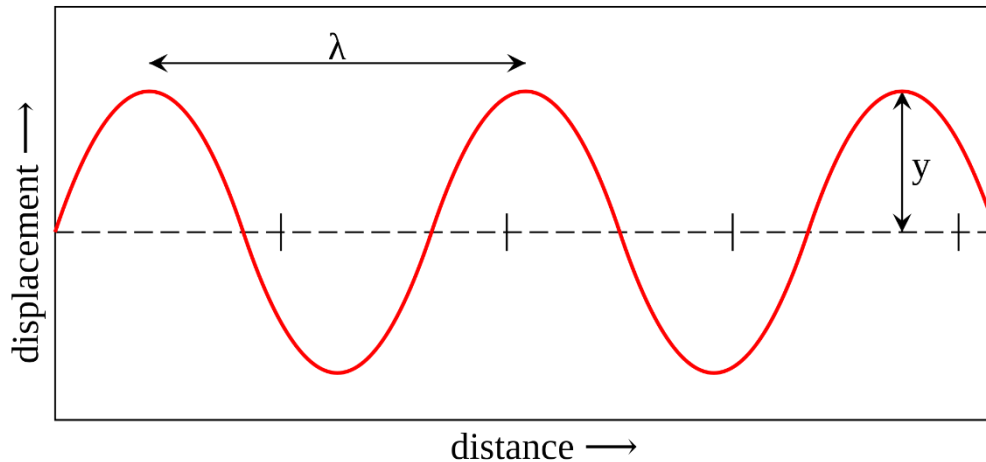

λ = wavelength
 y = amplitude

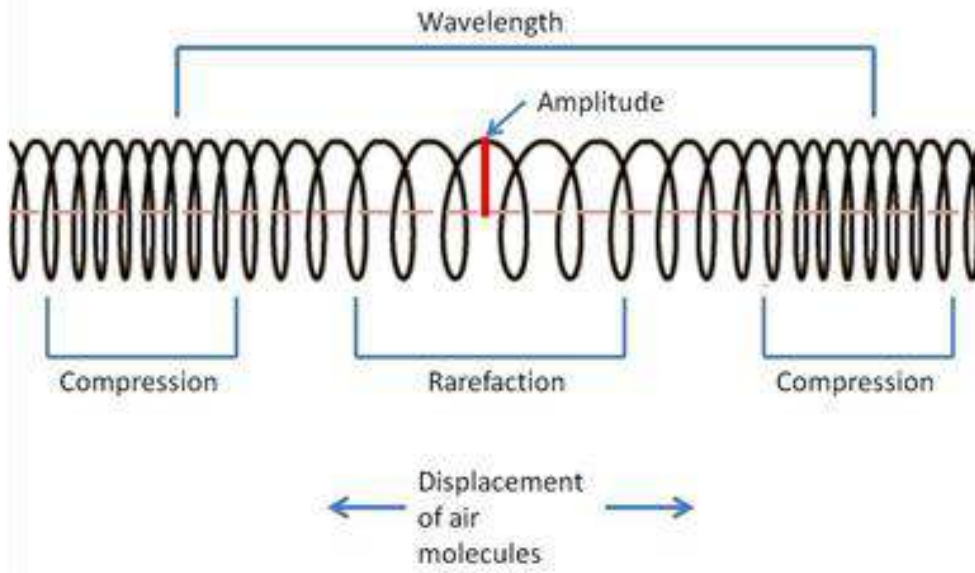

Wavelength (m) – the distance from one point on a wave to the same point on the next wave.

Amplitude (m) – the waves maximum displacement of a point on a wave from its undisturbed position.

Frequency (Hz) – the number of waves passing a point per second.

Period (s) - the time taken to produce one complete wave.

The displacement of a transverse wave is described as **peaks and troughs**. In a longitudinal wave these are described as **compressions and rarefactions**.

Properties of waves

Wave speed and wave period calculations

Wave speed is the speed at which energy is transferred by the wave (or how quickly the wave moves) through the medium it is travelling in.

$$\text{Wave speed (m/s)} = \text{Frequency (Hz)} \times \text{Wavelength (m)} \quad v = f \lambda$$

Wave period (T) is the time it takes one complete wave to pass a point (in seconds).

$$\text{Period (s)} = 1 / \text{Frequency (Hz)} \quad T = 1/f$$

The wave opposite has a frequency of 0.5Hz and a wavelength of 6cm (0.06m). Calculate the wave period and the wave speed.

$$\text{Wave period} = 1/f \quad T = 1/0.5 = 2s$$

$$\text{Wave speed} = f \times \lambda \quad v = 0.5 \times 0.06 = 0.03\text{m/s}$$

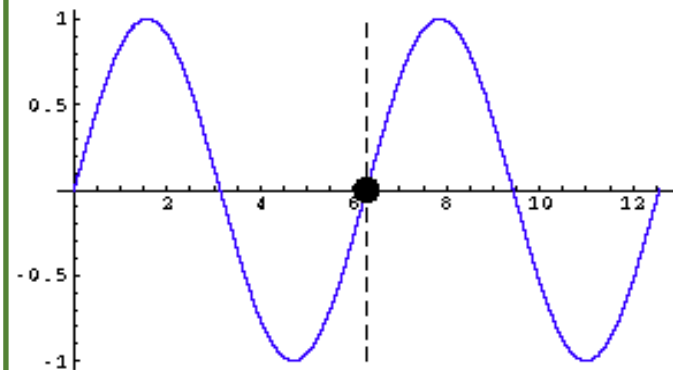

Properties of waves

Method for measuring the speed of sound waves in air



100m



The cannon fires and the stopwatch is started (you can see a flash of light which takes almost zero time to travel 100m). When the sound reaches the observer the stopwatch is stopped. The time was **0.3s**
This will give the time for sound to travel **100m**.

Speed (m/s) = Distance (m) / Time (s)

Speed of sound = 100 / 0.3 = 333.3m/s

In the laboratory, a sound from a loudspeaker passes two microphones a set distance apart. The time recorded for the sound to travel this distance is measured and speed is calculated using the same formula as above.

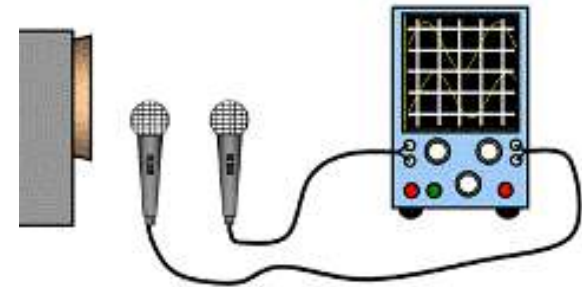

Properties of waves

Method for measuring the speed of ripples on a water surface

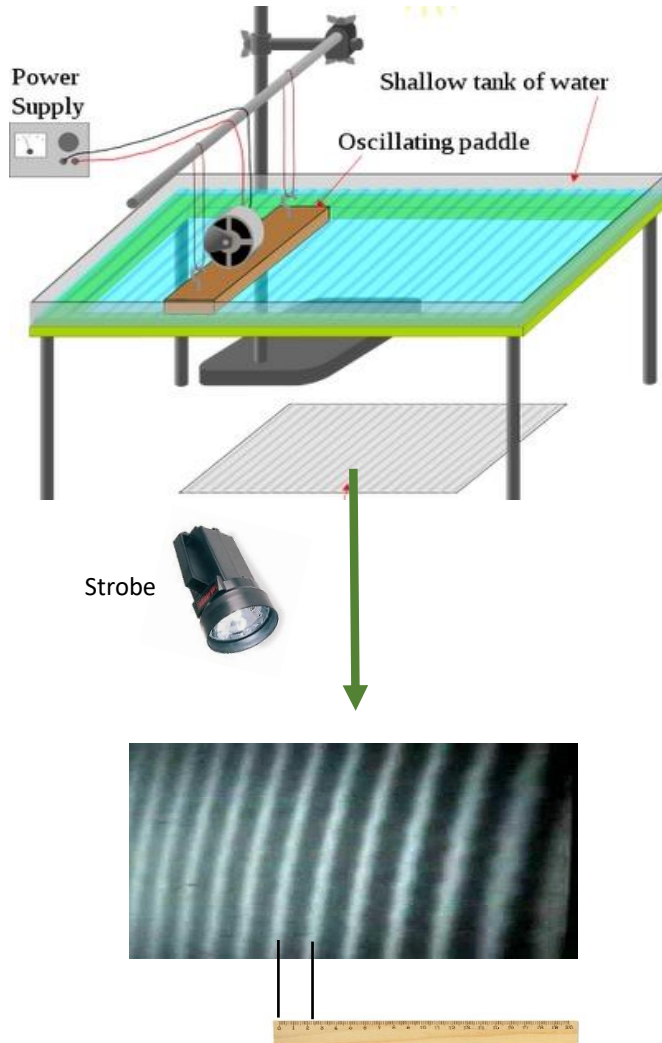

A ripple tank is used to make waves which are seen under the glass tank.

A strobe light has its frequency of flashes adjusted until the wave appears stationary – **this is the frequency of the water wave.**

Then, the **wavelength** of the water wave is measured by using a ruler to measure the distance from one peak to the next peak (white line to white line). This is converted to **metres.**

Wave speed (m/s) = Frequency (Hz) x Wavelength (m)

If the frequency of the water wave is 5Hz and the wavelength is 0.6cm:

wave speed = 0.5 x 0.006 = 0.03m/s

Sound waves changing medium (physics only)

When a **sound wave travels from one medium to another** e.g. air to water, the **frequency remains the same**. This is because frequency is a property of the object producing the sound, not the medium it travels through.

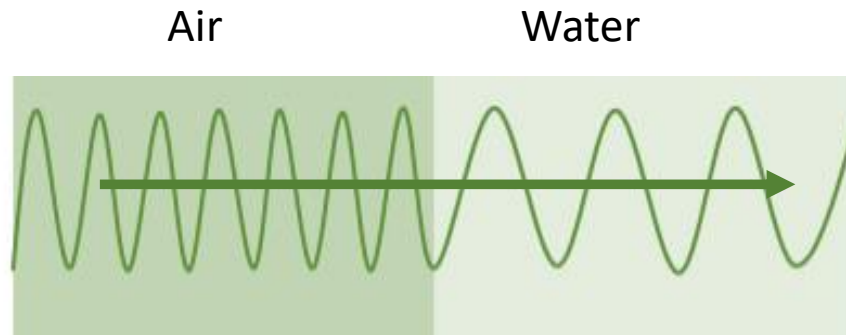

The sound wave will travel faster in water than air.

Remember, Wave speed (m/s) = Frequency (Hz) x Wavelength (m) or $f = v / \lambda$.

So, if the **frequency remains the same**, as **velocity increases**, the **wavelength must also increase** proportionally.

If a sound wave has a frequency of 260Hz:

Speed of sound in air = **330m/s.**

Speed of sound in water = **1500m/s.**

λ in air = $330 / 260 = \mathbf{1.27m}$

λ in water = $1500 / 260 = \mathbf{5.77m}$

Reflection of waves (physics only)

When light waves strike a boundary they can be **reflected**, **absorbed** or **transmitted** depending on the substance they strike.

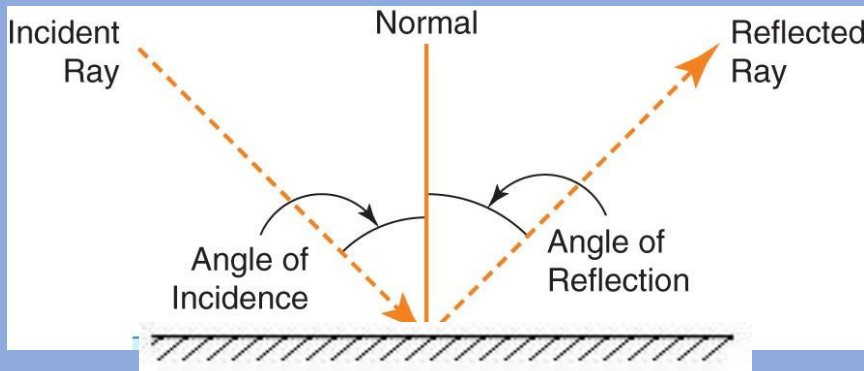
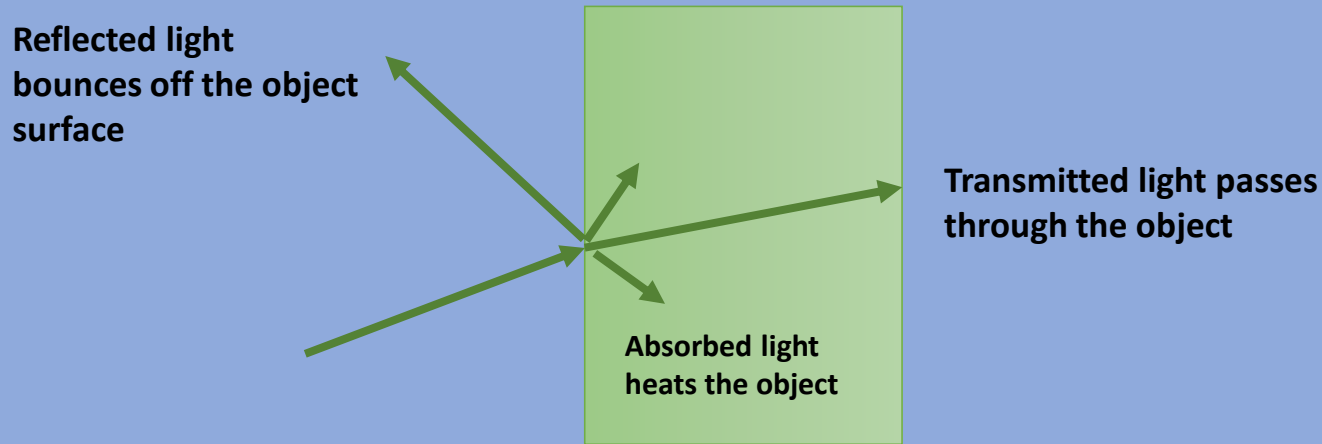

Light reflected from a specular surface, e.g. a mirror, reflects at the **same angle** it strikes the mirror.

**Angle of incidence (i) =
angle of reflection (r)**

Sound waves (physics only) (HT)

Sound waves can travel through solids causing **vibrations in the solid**.

In the ear, sound waves cause the **ear drum** and other parts to vibrate which causes the sensation of sound. The conversion of sound waves to solids only happens over a **limited frequency range**. This restricts the human hearing range to between **20Hz and 20,000Hz (20kHz)**.

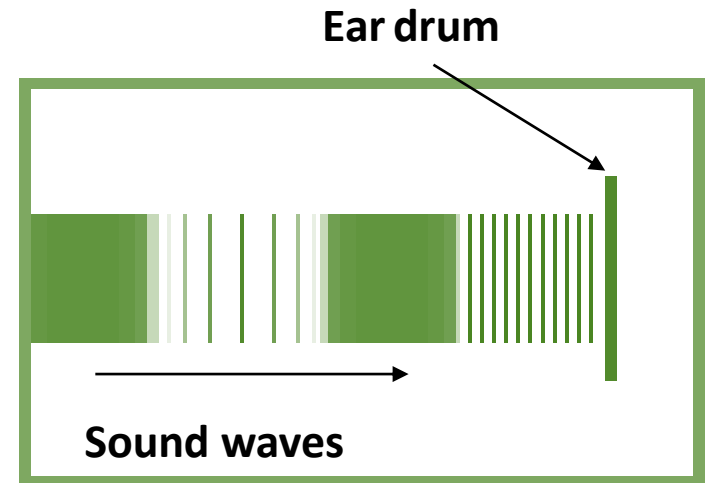
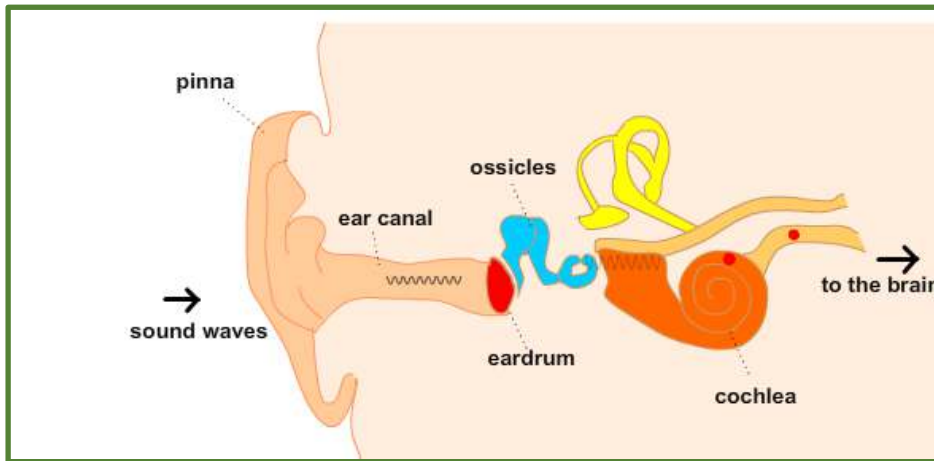

Waves for detection (physics only) (HT)

Ultrasound waves used for detection

Ultrasounds are sound waves with a higher frequency than humans can hear.

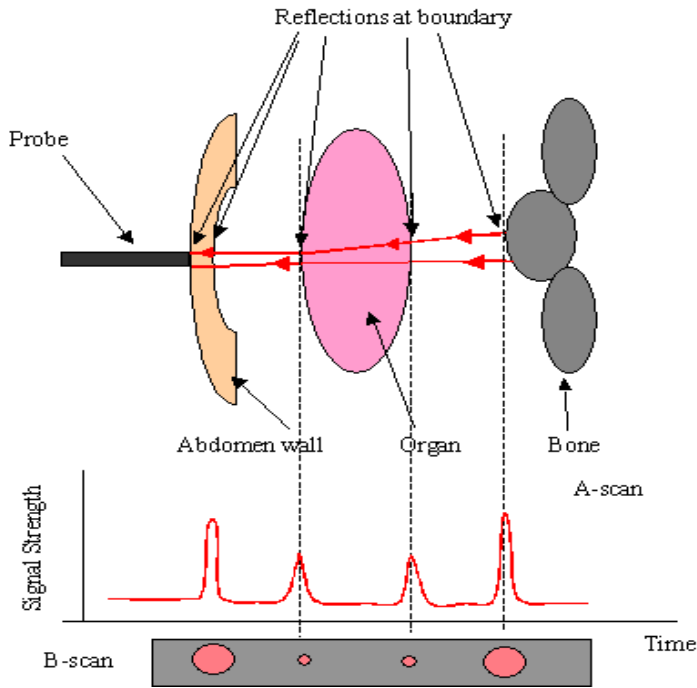

Ultrasound waves are **partially reflected** when they meet a **boundary** between **two different media**.

The **time taken** for the reflections to meet a detector can be used to determine how far away the boundary is. Ultrasound waves can therefore be used for medical imaging.

A similar technique, using **higher frequencies**, can be used in industry to detect flaws and cracks inside castings. This could prevent a potentially dangerous casting being used, for example, in an aircraft engine.

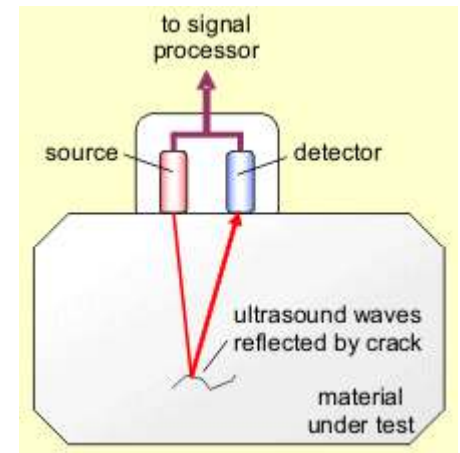

Waves for exploration (physics only) (HT)

Seismic waves used for exploration

Earthquakes produce P and S waves.

P waves: fast longitudinal; travel at different speeds through solids and liquids.

S waves: slower transverse; cannot travel through liquids.

This information can be used to determine the size, density and state of the Earth's structure. As S waves do not penetrate the outer core, they can not be used to determine whether the inner core is liquid or solid.

The study of seismic waves provided new evidence that led to discoveries about parts of the Earth which are not directly observable.

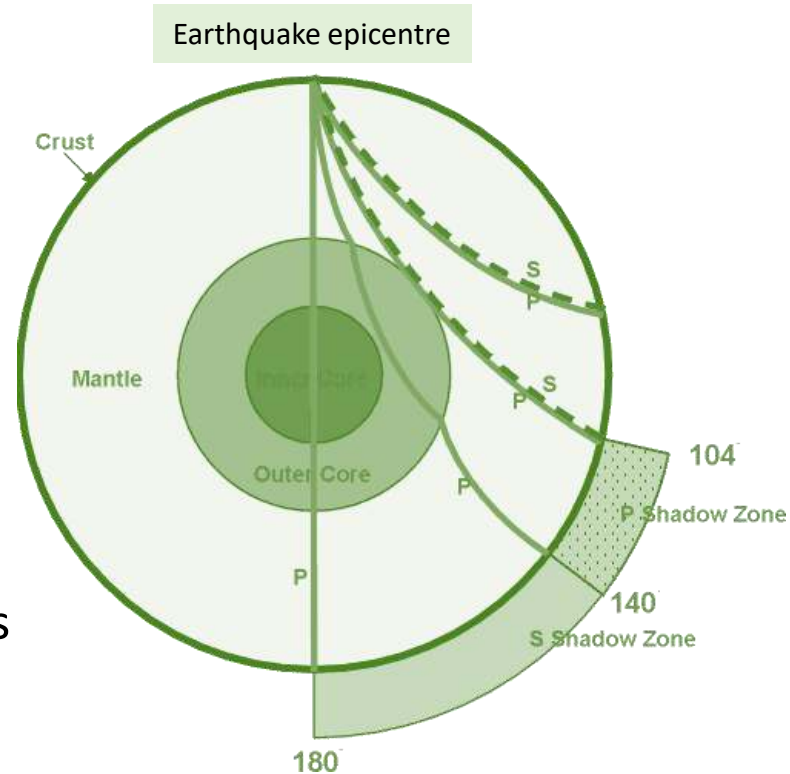

Waves for exploration (physics only) (HT)

Echo sounding

Echo location or SONAR uses high frequency sound waves to **detect objects in deep water** (shipwrecks, shoals of fish) and **measure water depth**.

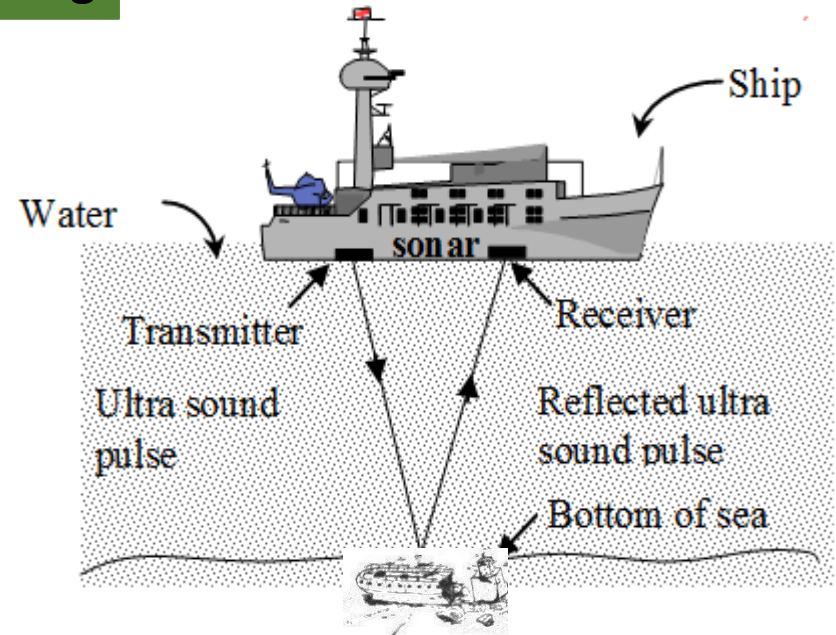

Ultrasound waves travel at **1500m/s** in sea water. The transmitter sends out a wave which is received **4.6s** later. The depth of water under the ship can be calculated as:

Distance (m) = speed (m/s) x time (s) so: distance = **1500 x 4.6 = 6900m**

Remember, this is the time to go to the bottom and back.

Therefore depth = $6900 / 2 = 3450\text{m}$

QuestionIT!

Waves in air, fluids and solids

- Transverse and longitudinal waves
- Properties of waves
- Reflection of waves (physics only)
- Sound waves (physics only) (HT)
- Waves for detection and exploration (physics only) (HT)

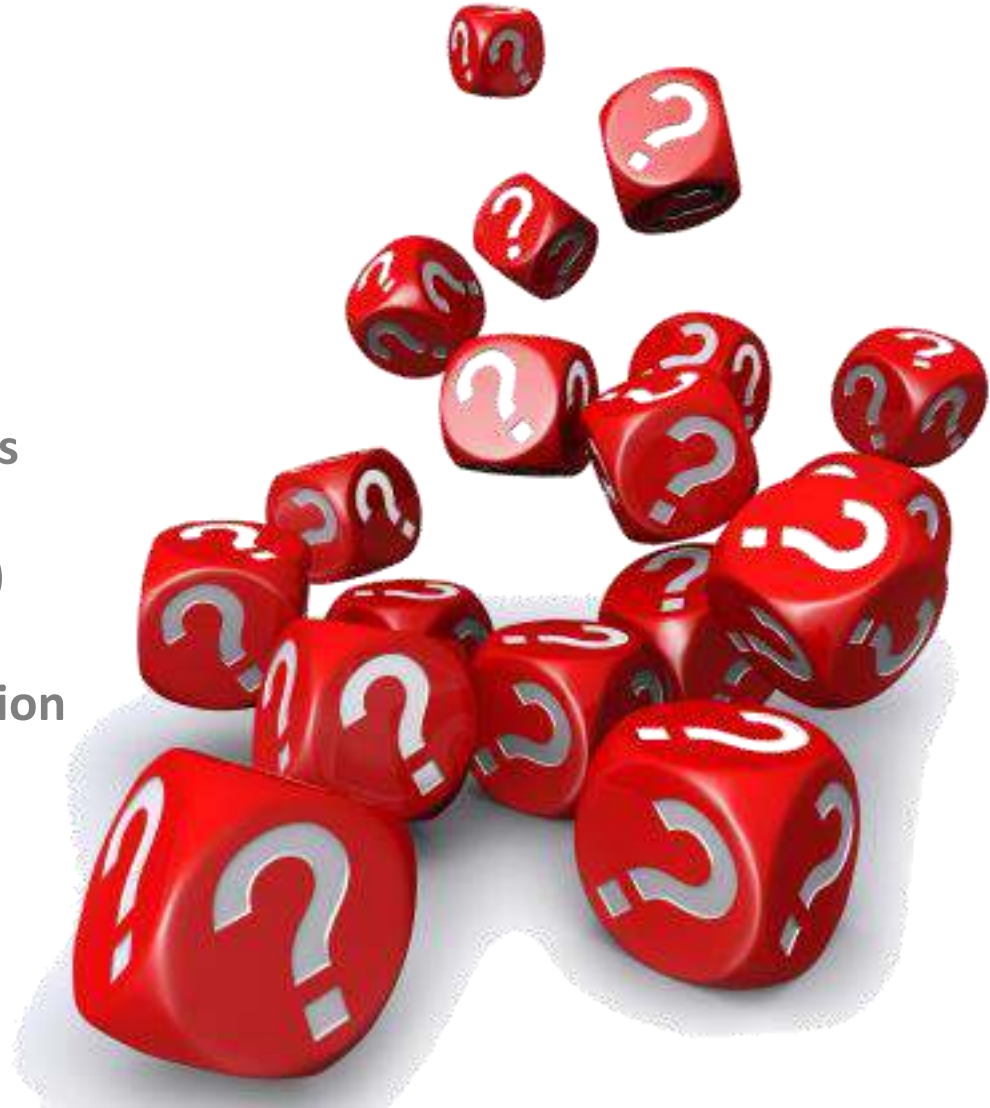

Waves in air, fluids and solids – QuestionIT

1.

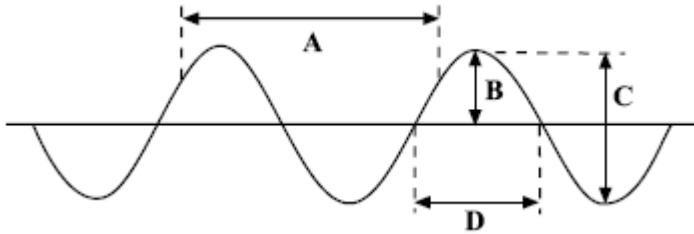

- What type of wave is shown above?
- Which letter represents the amplitude of the wave?
- Which letter shows the wavelength?

2. Draw a longitudinal wave and label a compression, rarefaction and the wavelength.

3. The diagram shows a cork floating on a water wave which has a frequency of 0.5 Hz. Which letter shows where the cork will be 2 seconds later?

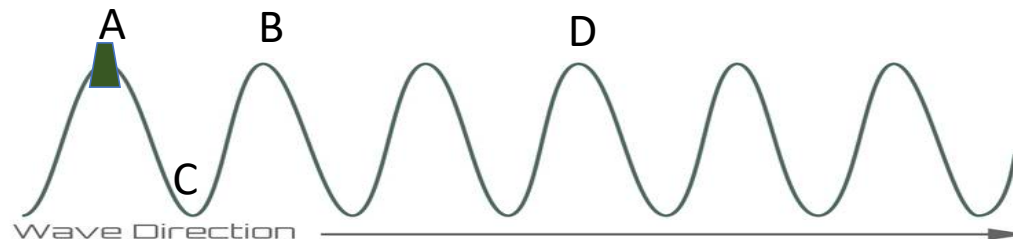

Waves in air, fluids and solids – QuestionIT

4. What is meant by the period of a wave?
5. A wave has a period of 0.25s. Calculate the frequency of this wave.

$$T = 1 / f$$

6. A sound wave has a frequency of 240Hz and a wavelength of 1.38m. Calculate the velocity of this sound wave. Show clearly the formula you use for this calculation.

7. The diagram shows a ripple tank, used to generate waves in the laboratory. Describe the measurements that must be made in order to calculate the velocity of water waves in the tank.

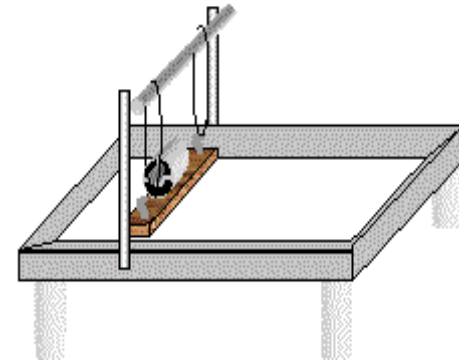

Waves in air, fluids and solids – QuestionIT

8. (Physics HT only) The sound waves from a noisy jet travel from the air into water. Which property of the wave will not change?
9. (Physics HT only) The Eiffel Tower is made of iron. The speed of sound in iron is 4000m/s . Someone at the top hits the iron with a hammer and the sound can be heard at the bottom 0.08s later. How tall is the Eiffel Tower?
10. (Physics only) The diagram shows a light ray striking a plane mirror. Copy and complete the diagram (include all labels).

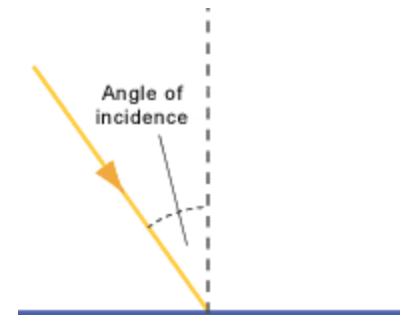

Waves in air, fluids and solids – QuestionIT

11. (Physics only) When light strikes a black curtain, very little light gets reflected. What happens to the light?
12. (Physics only) Explain why you cannot see your reflection when you look into a piece of white plastic held in front of you.
13. (Physics only) When waves flow from deep water to shallow water the wave can bend (refract). What happens to the speed of the wave to allow this to happen?

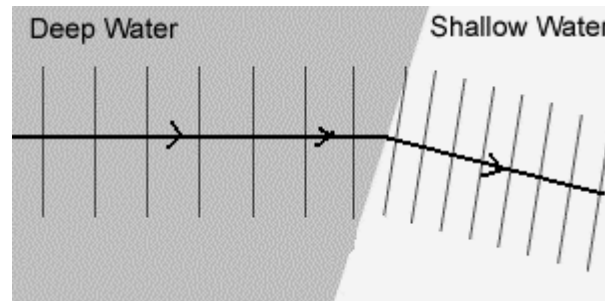

Waves in air, fluids and solids – QuestionIT

14. (Physics HT only) Describe how sound waves in the air are converted to vibrations in solids by the ear.
15. (Physics HT only) Which of the following represents the frequency range of human hearing?
- 200Hz to 2000Hz 20Hz to 20 000Hz 2000Hz to 200 000Hz
16. (Physics HT only) What are ultrasound waves?

Waves in air, fluids and solids (physics only) – QuestionIT

17. (Physics HT only) The picture shows the ultrasound image of an unborn baby. Explain how ultrasound is able to produce an image from the outside of the mother.



18. (Physics HT only) Seismic waves are described as P or S waves. Copy the table and put ticks in the correct column to show the difference in these two seismic waves.

Wave type	Longitudinal wave	Fastest wave	Can travel through liquid and solid
P wave			
S wave			

19. (Physics HT only) Describe how P and S seismic waves can be used to show part of the Earth's core is liquid.

AnswerIT!

Waves in air, fluids and solids

- Transverse and longitudinal waves
- Properties of waves
- Reflection of waves (physics only)
- Sound waves (physics only) (HT)
- Waves for detection and exploration (physics only) (HT)



Waves in air, fluids and solids – QuestionIT

1.

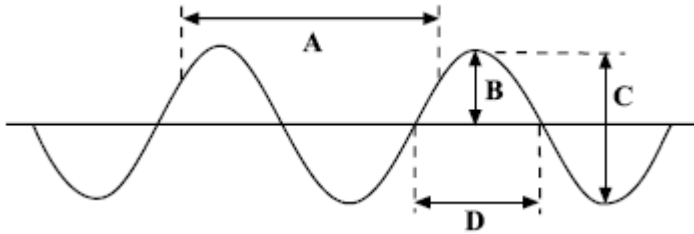

- What type of wave is shown above? **Transverse**
- Which letter represents the amplitude of the wave? **B**
- Which letter shows the wavelength? **A**

2. Draw a longitudinal wave and label a compression, rarefaction and the wavelength.

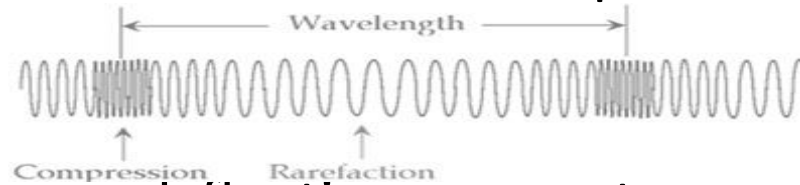

3. The diagram shows a cork floating on a water wave which has a frequency of 0.5 Hz. Which letter shows where the cork will be 2 seconds later? **A**

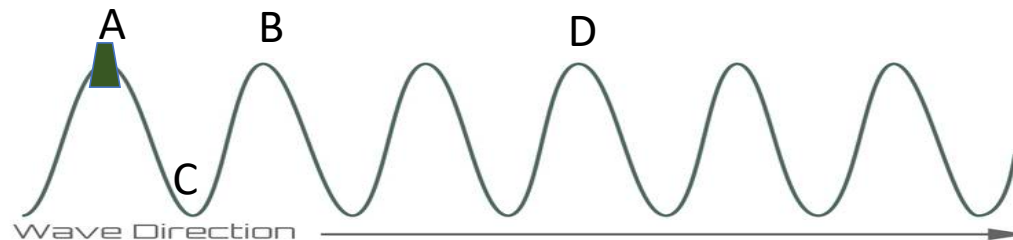

Waves in air, fluids and solids – QuestionIT

4. What is meant by the period of a wave?

Time taken to complete 1 full wave.

5. A wave has a period of 0.25s. Calculate the frequency of this wave.

$$T = 1 / f$$

$$f = 1/T \quad f = 1 / 0.25 \quad \text{Frequency} = 4\text{Hz}$$

6. A sound wave has a frequency of 240Hz and a wavelength of 1.38m. Calculate the velocity of this sound wave. Show clearly the formula you use for this calculation.

$$v = f\lambda \quad v = 240 \times 1.38$$

$$\text{Velocity of the wave} = 331.3\text{m/s}$$

Waves in air, fluids and solids – Question 17

7. The diagram shows a ripple tank, used to generate waves in the laboratory.

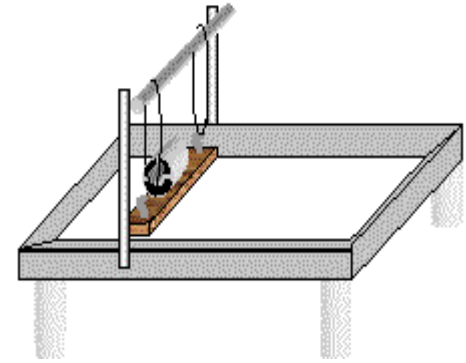

Describe the measurements that must be made in order to calculate the velocity of water waves in the tank.

Measure wave frequency with a strobe light and wavelength of a wave with a ruler then use $v = f \lambda$

or: measure time for a wave to travel a measured distance and use $s = d/t$

Waves in air, fluids and solids – QuestionIT

8. (Physics HT only) The sound waves from a noisy jet travel from the air into water. Which property of the wave will not change?

Frequency.

9. (Physics HT only) The Eiffel Tower is made of iron. The speed of sound in iron is 4000m/s. Someone at the top hits the iron with a hammer and the sound can be heard at the bottom 0.08s later. How tall is the Eiffel Tower?

$$s = d/t \quad d(\text{height}) = s \times t \quad \text{Height} = 4000 \times 0.08 = 320\text{m}$$

10. (Physics only) The diagram shows a light ray striking a plane mirror. Copy and complete the diagram (include all labels).
(angle of incidence = angle of reflection)

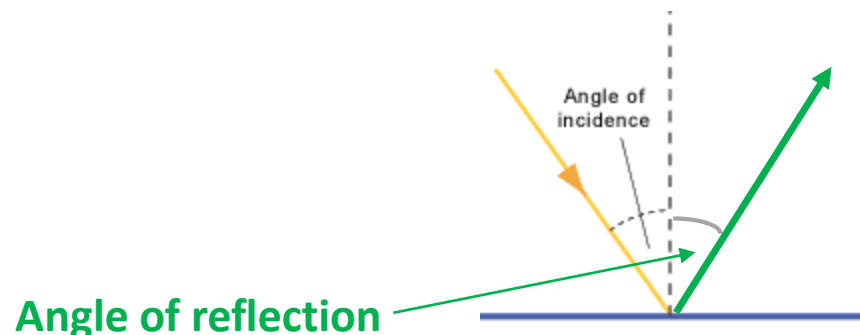

Waves in air, fluids and solids – QuestionIT

11. (Physics only) When light strikes a black curtain, very little light gets reflected. What happens to the light?

It is absorbed by the curtain as heat energy.

12. (Physics only) Explain why you can not see your reflection when you look into a piece of white plastic held in front of you.

Light rays are scattered in all directions – diffuse reflection.

13. (Physics only) When waves flow from deep water to shallow water the wave can bend (diffract). What happens to the speed of the wave to allow this to happen?

Waves slow down in shallow water.

Bottom of wave enters shallow water before top of wave. Therefore bottom of wave slows down before the top, causing the wave to bend.

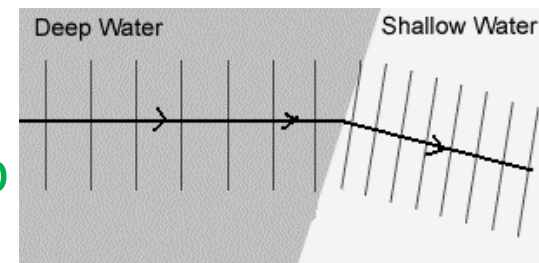

Waves in air, fluids and solids – QuestionIT

14. (Physics HT only) Describe how sound waves in the air are converted to vibrations in solids by the ear.

Compressions in the air cause the ear drum to flex inwards and outwards. This sets up vibrations of the bones in the inner ear.

15. (Physics HT only) Which of the following represents the frequency range of human hearing?

200Hz to 2000Hz

20Hz to 20 000Hz

2000Hz to 200 000Hz

16. (Physics HT only) What are ultrasound waves?

Sound waves with a frequency higher than humans can hear.

Waves in air, fluids and solids – QuestionIT

17. (Physics HT only) The picture shows the ultrasound image of an unborn baby. Explain how ultrasound is able to produce an image from the outside of the mother.



Ultrasounds penetrate the body. Some of the waves are reflected when they meet a boundary between two structures. These reflected waves are received at different times and are formed into an image.

Waves in air, fluids and solids (physics only) – QuestionIT

18. (Physics HT only) Seismic waves are described as P or S waves. Copy the table and put ticks in the correct column to show the difference in these two seismic waves.

Wave type	Longitudinal wave	Fastest wave	Can travel through liquid and solid
P wave	✓	✓	✓
S wave			

19. (Physics HT only) Describe how P and S seismic waves can be used to show part of the Earth's core is liquid.

Detectors on the opposite side of the Earth to the earthquake epicentre can record both P and S waves. Only P waves are detected meaning S waves can not penetrate through the Earth. As S waves can not travel through liquids, it is deduced that part of the core is liquid .

LearnIT! KnowIT!

Electromagnetic Waves

- Types of electromagnetic waves
- Properties of electromagnetic waves
- Uses and applications of electromagnetic waves
- Lenses (physics only)
- Visible light (physics only)



Types of electromagnetic waves

Electromagnetic waves are transverse waves that transfer energy from the wave source to an absorber.

Electromagnetic waves form a **continuous spectrum** from the shortest gamma waves ($< 10^{-11}\text{m}$ wavelength) to radio waves ($> 100\text{km}$ wavelength).
Shorter wavelengths have a **higher frequency** and **higher energy**.

All electromagnetic waves travel at the same velocity in a vacuum:
300 000 000m/s.

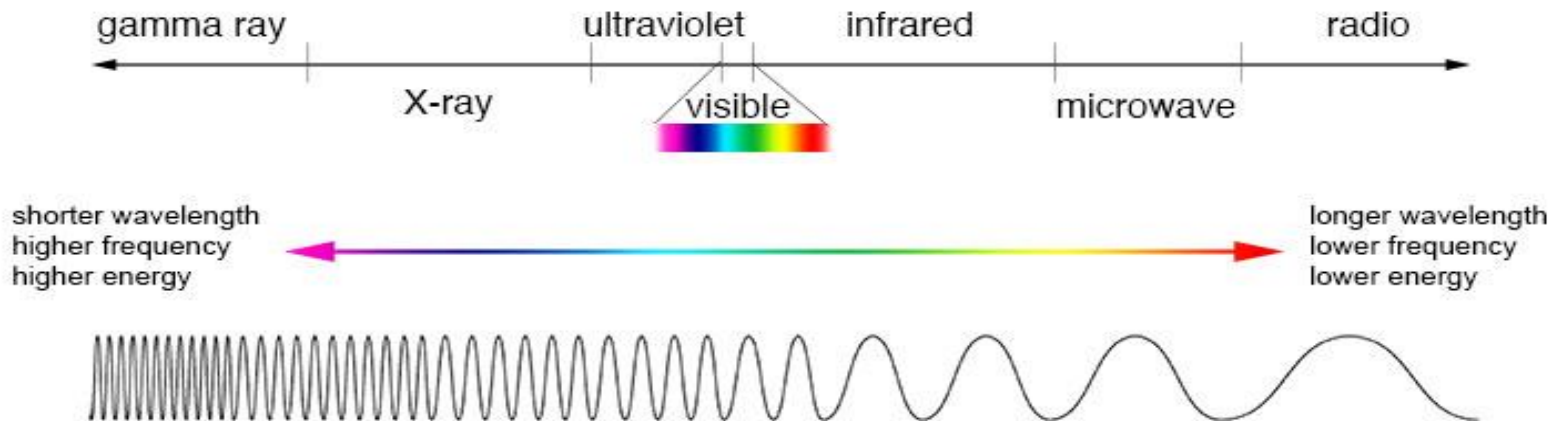

Our eyes are only able to detect a small range of these waves shown as the visible range above. Some animals can see in ultra violet and some can detect infra red.

Types of electromagnetic waves

Examples of transfer of energy by electromagnetic waves

Heater



Infra red waves



Detected by heat sensors in the hand



Torch



Visible light waves

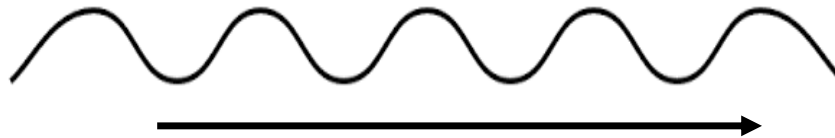

Detected by cells in the retina



Radio transmitter



Radio waves



Detected by the aerial in the radio



Properties of electromagnetic waves 1 (HT)

Absorption, transmission and reflection of different wavelengths of light

Most materials absorb some of the light falling on it. A white or shiny surface reflects most of the incident light whereas a black surface absorbs most wavelengths of light.

Absorbed light is changed into a **heat** energy store so is not re-radiated as light.

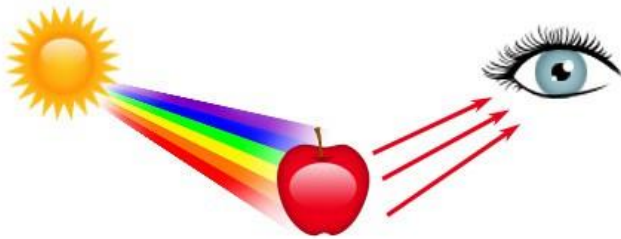

White light/sunlight is made from all the wavelengths of light in the spectrum. A red object appears red in white light because it only **reflects** the red wavelengths of light, all other colours are absorbed.

If light **transmits** through a coloured object, the colour passing through is the colour we see. As with reflected light, all other wavelengths of light are absorbed by the transparent or translucent material.

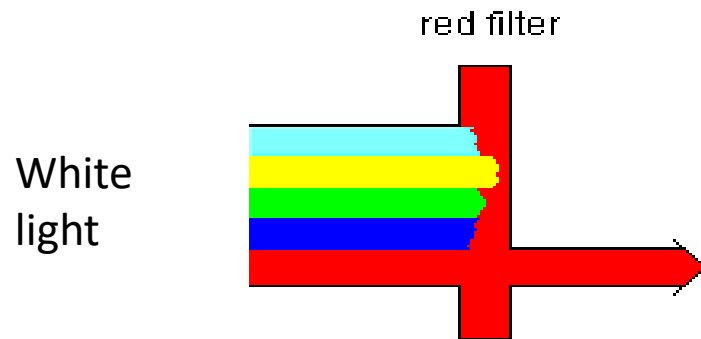

Properties of electromagnetic waves 1 (HT)

Refraction of different wavelengths of light in different materials

Refraction of electromagnetic waves occurs because the **wave changes speed** when it enters a substance of different **optical density**.

The light wave will only refract if one side of the wave strikes the new material before the other side.

The amount of refraction is different for materials of different optical density as seen in Figure 1 opposite.

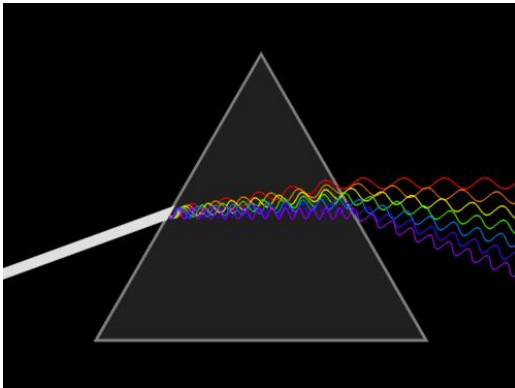
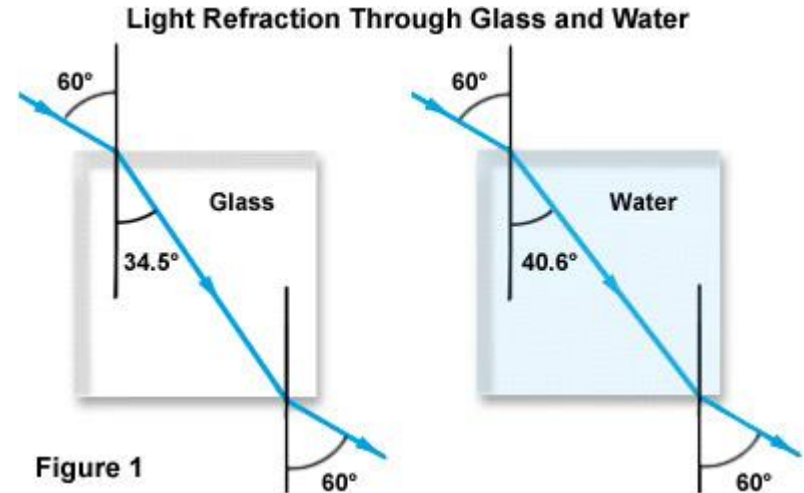

Different wavelengths of light are **diffracted by different amounts**, resulting in a spectrum of colour being produced when white light is refracted (dispersed) by a prism.

Properties of electromagnetic waves 1

Refraction of waves at a boundary– ray diagrams

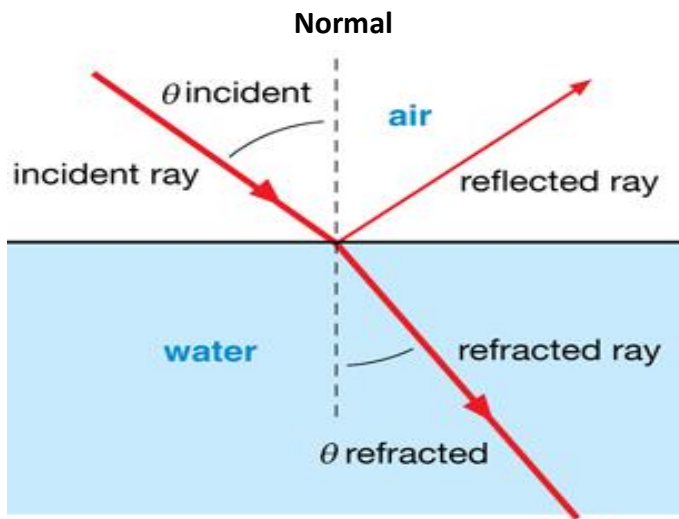

When light strikes a transparent material, some of the light may be reflected but some will also be **refracted**.

When light enters a substance of greater density, it will be bent (refracted) **towards the normal line**.

Angle of incidence > angle of refraction

When light enters a substance of lower density, it will be bent (refracted) **away from the normal line**.

Angle of incidence < angle of refraction

Properties of electromagnetic waves 1 (HT)

Explaining refraction using wave front diagrams

- The **incident ray** is shown as wave fronts where all the waves are in phase with each other. This is drawn as a wave line at right angles to the direction in which the wave is travelling.
- The incident ray strikes the denser medium 2 at an angle.
- When the wave front hits a denser material it **slows down**. One side of the wave front hits before the other side, so slows down first.
- This causes the wave front to **bend towards the normal line**. Wave fronts will be closer together as the velocity is decreased. Frequency is unchanged.

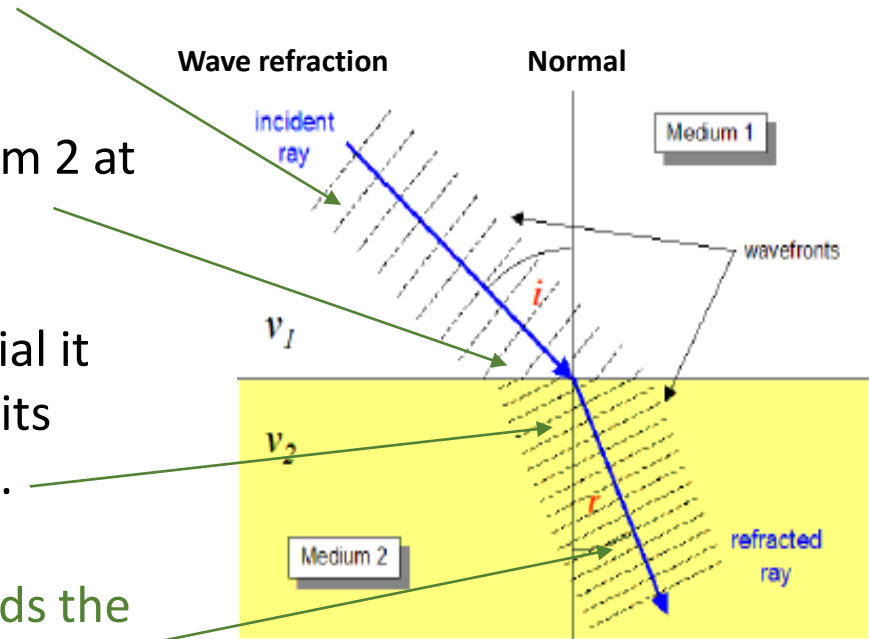

Properties of electromagnetic waves 1 (HT)

Absorption and radiation of infra red waves (required practical)

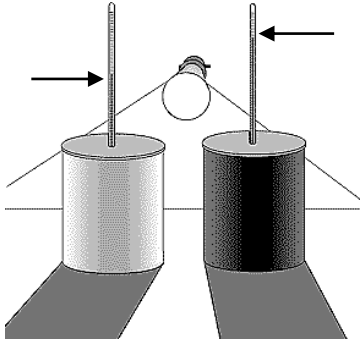

Black surfaces absorb infrared waves better than white or shiny surfaces.



Black surfaces also emit infrared radiation quicker than light coloured surfaces

BEST EMITTER

WORST EMITTER



This is the reason black cars and black curtains get hot in sunshine.

Petrol storage tankers are painted white or polished to reflect the sun's IR heat waves.

A black kettle would radiate IR heat quicker than a shiny silver kettle and so would cool down faster. Car radiators are painted black to help them emit IR heat quickly.

Properties of electromagnetic waves 2 (HT)

Radio waves

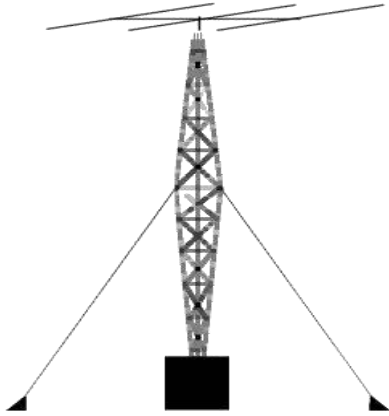

A radio wave is transmitted at the same frequency as the a.c. current which produced it.

Radio signals are produced when an **alternating current** is passed through a wire in a radio transmitter. The **oscillating (vibrating) particles** in the wire produce a **radio wave** which is modulated and boosted so it can carry the signal over a great distance.

When this radio signal reaches another antenna (e.g. aerial on a radio) the **radio waves cause oscillations in the wire**. This produces an alternating current of the **same frequency as the radio signal**.

Properties of electromagnetic waves 2

Atoms and electromagnetic waves

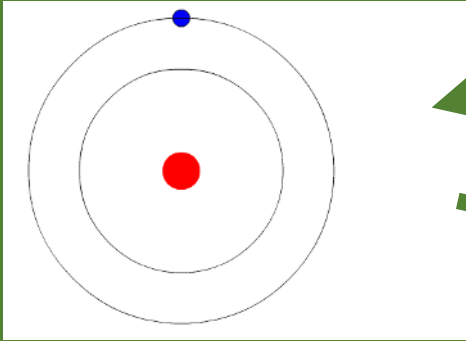

Changes within the nucleus of an atom can result in the emission of gamma waves. This occurs during the radioactive decay of some unstable atoms.

could be:
light, heat, electricity, X rays etc

will be a type of
electromagnetic radiation i.e.
X ray, ultra violet, visible,
infra red, microwave or radio waves.

Atoms can receive energy from external sources.

This energy can cause electrons to “jump” to a .

When the electron falls back to its original energy level it will release the stored energy in the form of a

Properties of electromagnetic waves 2

Health risks of high energy electromagnetic radiations

High frequency radiations have **high energy**. They can have a **hazardous** effect on **human tissue**.

UV, X ray and gamma waves are high energy radiations.

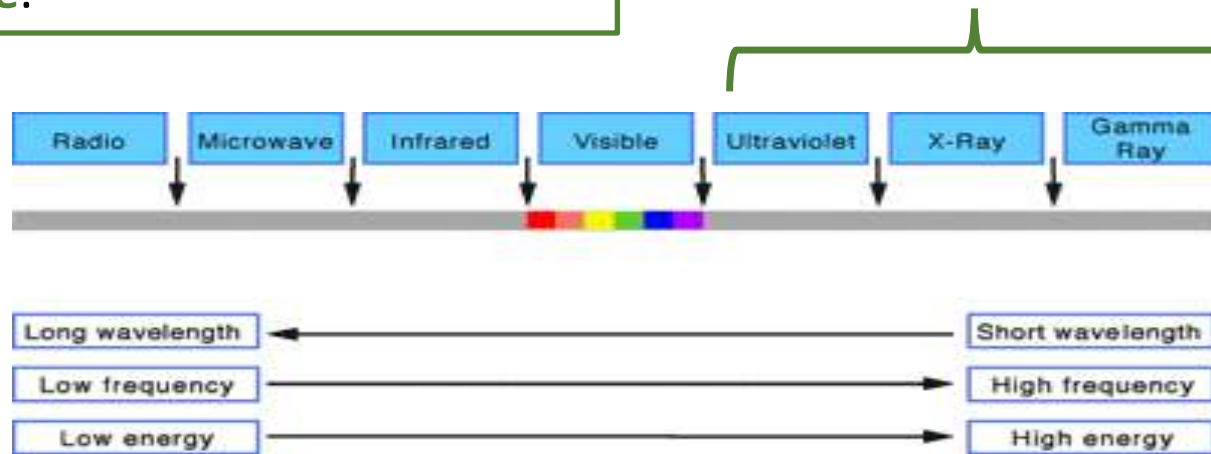

The hazard from high energy radiations also depends on the **dose**. Radiation dose is a measure of the risk when exposed to these radiations. Radiation dose is **measured in Sieverts**.

Ultra violet waves can cause sunburn, ageing of the skin and skin cancer.

X rays and gamma rays are ionising radiations that can cause mutations of genes which could result in cancer.

Uses and applications of electromagnetic waves 2

	Type	Application	Suitability (HT)
<p>Low frequency low wavelength</p> 	Radio	Television and radio	Travel through atmosphere for long distances
	Microwave	Satellite communications. Cooking food	Travel through atmosphere; agitates water molecules causing them to heat food
	Infrared	Electrical heaters, cooking food, infrared cameras	Heat energy transfer; detection of heat waves
	Visible	Fibre optic communications	Retina can detect light waves; light can travel through optic fibres and carry information
	Ultraviolet	Energy efficient lamps, sun tanning	Some materials can absorb UV and re-emit as visible, energy efficient, skin reacts to UV light causing tanning
	X-rays	Medical imaging and treatment	Pass through soft tissue, penetrate materials to different extents so can produce image

Waves – Lenses (physics only)

Lenses refract light to produce an image at a principal focus.

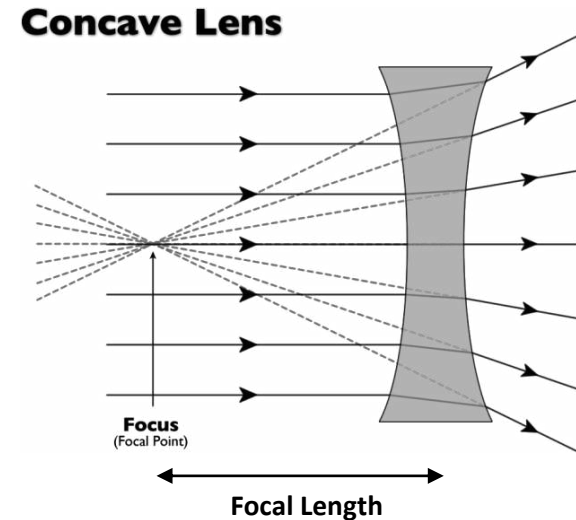
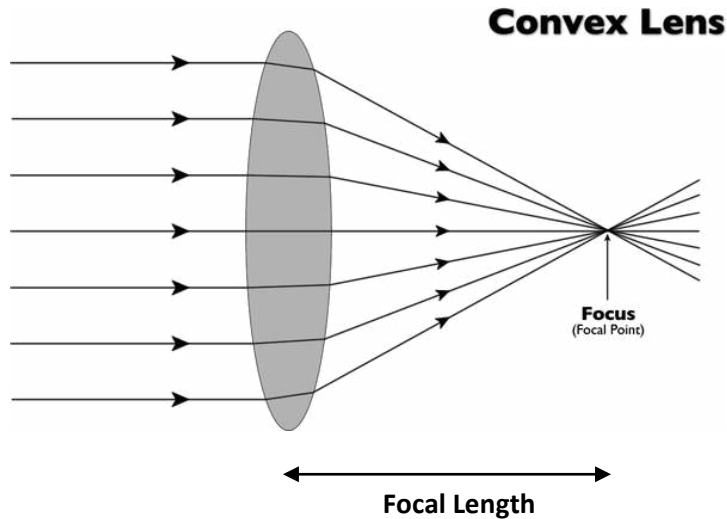

↑
↓
Convex lenses are also called converging lenses. They can produce **real or virtual images**.

Concave lenses are also called diverging lenses. They always produce **virtual images**.

A **real image** is the image formed where the **light rays are focussed**.
A **virtual image** is one from which the light rays **appear to come from** but don't actually come from that image.

Waves – Lenses (physics only)

Magnification of a lens is a **ratio** and so has **no units**.
Image height and object height should both be measured in **mm** or **cm**.

$$\text{Magnification} = \frac{\text{Image height}}{\text{Object height}}$$

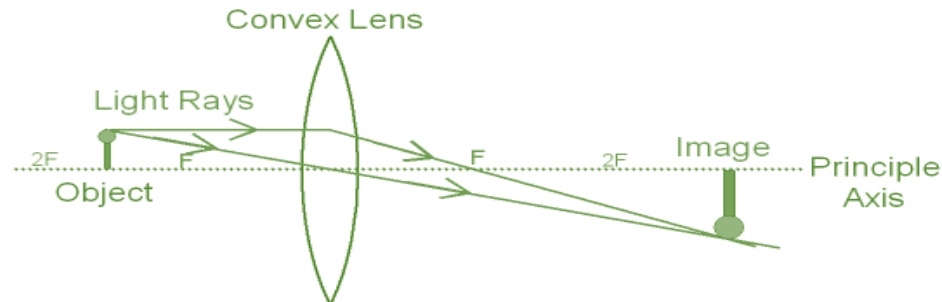

In the above diagram, the object height is **12mm** and the image size is **24mm**.
The magnification of the lens is:

$$\text{Magnification} = \frac{24}{12} = 2$$

The **magnification** is **x2**. As this is a ratio there are **no units** for magnification.

The image type and magnification will also depend on the position of the object.

Waves – Lenses (physics only)

The image produced by a convex lens depends on the position of the object. The object can be placed anywhere between the lens, the focal length (F) and twice the focal length ($2F$) of the lens.

Object at the focal length (F)

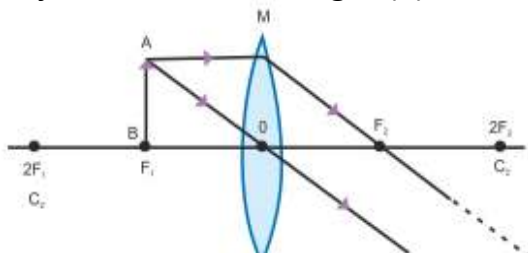

Object closer than the focal length ($<F$)

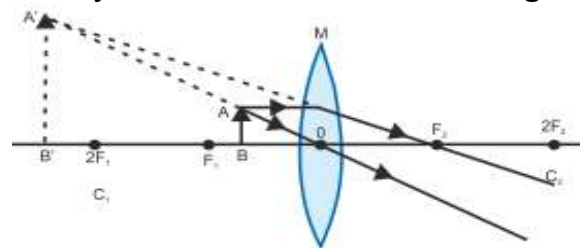

Object at more than twice the focal length ($>2F$)

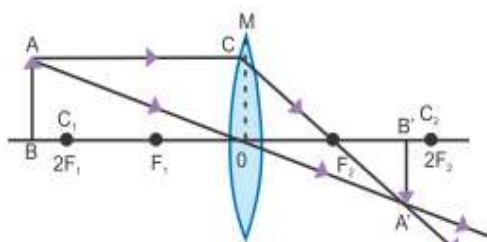

Object at twice the focal length ($2F$)

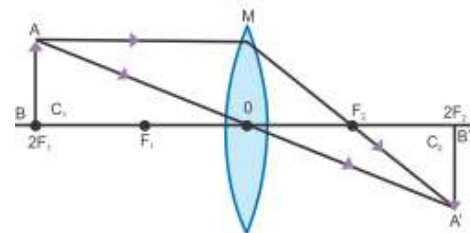

Object between F and $2F$

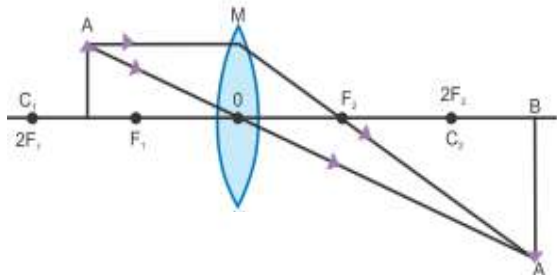

Object at infinity

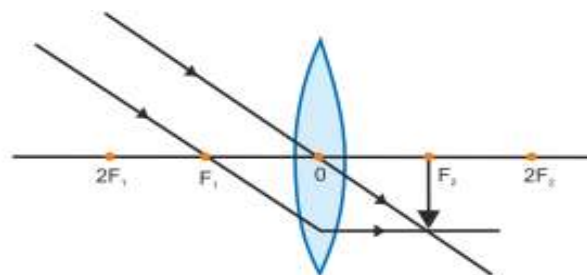

Waves – Visible light (physics only)

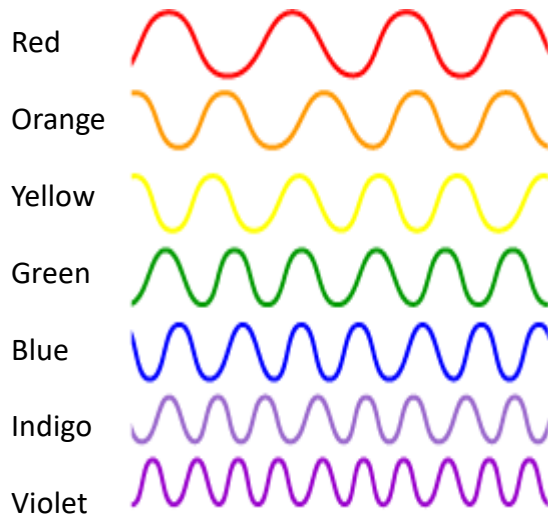

Each colour within the visible spectrum has its own narrow band of **wavelength** and **frequency**.

Colour filters work by **absorbing certain wavelengths** (and colour) and **transmitting other wavelengths** (and colour).

The colour of an opaque object is determined by which wavelengths of light are more **strongly reflected**.

Wavelengths that are **not reflected are absorbed**.

If **all wavelengths are reflected** equally the object will appear **white**. If **all the wavelengths of light are absorbed** equally the object will appear **black**.

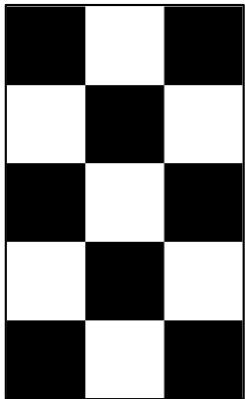

Waves – Visible light (physics only)

Light reflecting off a smooth, flat surface produces **specular reflection**.

When light reflects off a rough surface, **diffuse reflection** occurs. This is why you can not see your image in a piece of white paper even though it reflects most of the light striking it.

Specular reflection

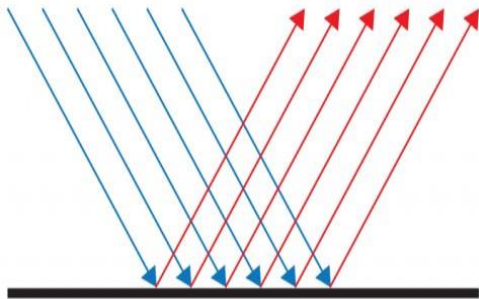

Diffuse reflection

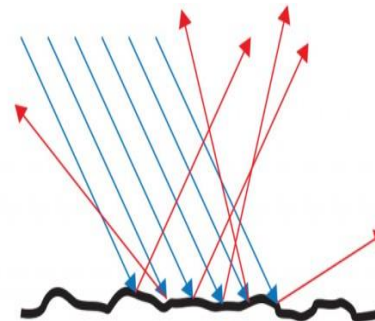

Waves – Visible light (physics only)



Transparent – a material that allows objects behind it to be seen clearly as if nothing was in the way.

e.g. glass, perspex



Translucent – a material that allows objects to be seen through them but not as clearly or sharply as a transparent material.

e.g. tracing paper, frosted glass



Opaque – a material that may or may not allow light through to the object behind. It would be difficult to tell what object is behind an opaque material.

e.g. paper, wood

QuestionIT!

Electromagnetic Waves

- Types of electromagnetic waves
- Properties of electromagnetic waves
- Uses and applications of electromagnetic waves
- Lenses (physics only)
- Visible light (physics only)



Electromagnetic waves – QuestionIT

1. What type of waves are electromagnetic waves?
2. List the main electromagnetic waves in order from lowest to highest frequency.
3. Which of the following is the speed of electromagnetic waves in a vacuum?

300 m/s 300 000m/s 300 000 000m/s
4. Which colour of light has the longest wavelength?
5. Describe one piece of evidence to show that light waves do not need a medium to travel from one place to another.

Properties of electromagnetic waves – Question 1

6. The four surfaces below are heated equally with infrared (IR) radiation.



a. Which surface will absorb the most IR radiation?

b. Which surface will reflect the most IR radiation?

7. The diagrams show three waves travelling from air into different materials.

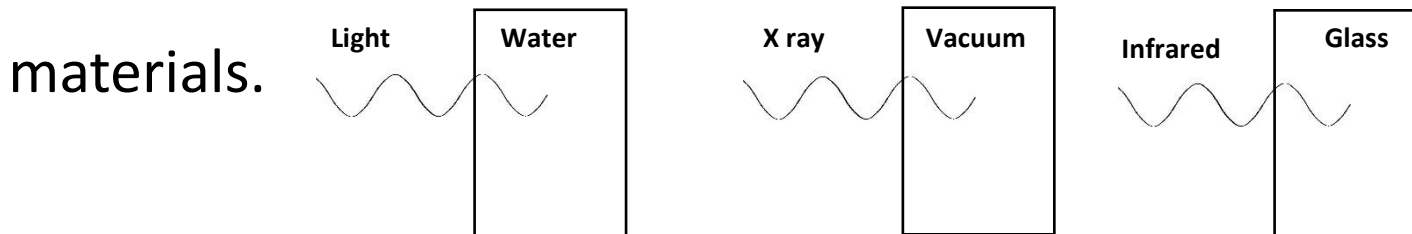

Which wave will be travelling the slowest?

Properties of electromagnetic waves – QuestionIT

8. The light wave shown below meets a boundary between glass and air. Continue the light ray to show its path after passing the boundary.

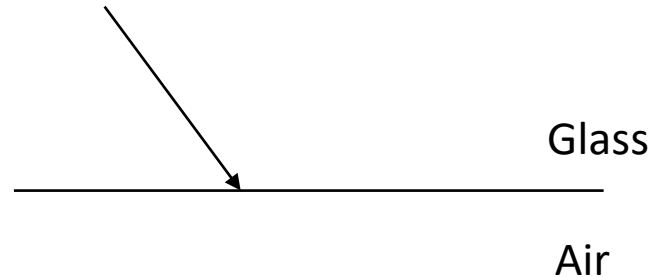

9. (HT) The wave front below is travelling from air into water. Explain why the wave front bends.

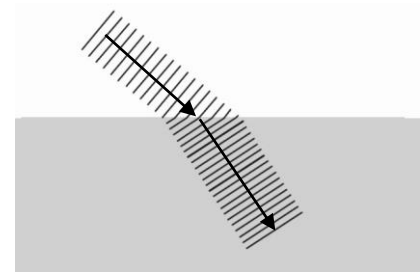

10. Infrared rays strike a black tile. Will the waves mainly be reflected, refracted or absorbed?

Properties of electromagnetic waves – QuestionIT

11. (HT) Radio waves are transmitted through the air and received by aerials.

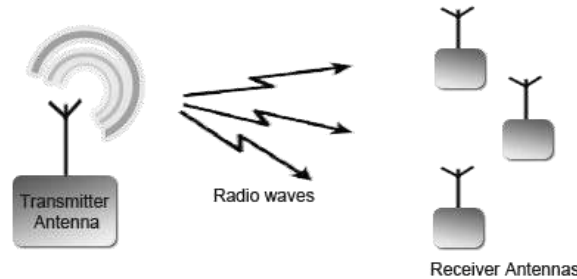

- How are radio waves produced in the transmitter aerial?
- What is produced in the receiving antenna when radio waves are absorbed?

12. Most electromagnetic waves are produced from energy changes in electron levels. How does gamma wave production differ from this?

Properties of electromagnetic waves – QuestionIT

13. Which three types of electromagnetic waves can cause damage to cells in the body?

14. What is meant by radiation dose?

15. The chart shows the average radiation dose a UK person is exposed to in a year.

a) What percentage of the radiation dose comes from natural sources?

b) Give **two** reasons why a person could receive a higher dose of background radiation.

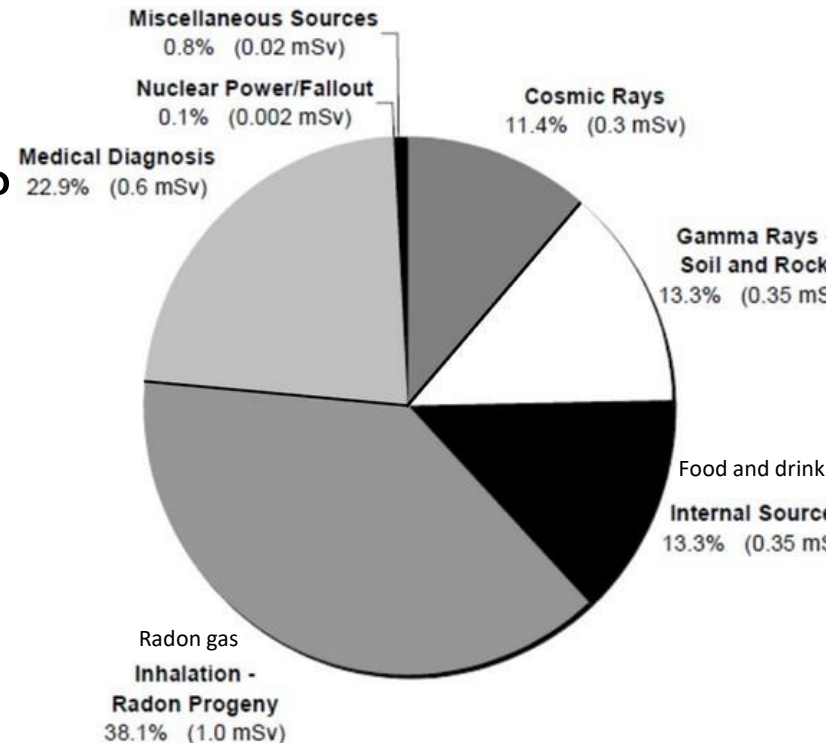

Uses of electromagnetic waves – QuestionIT

16. State which type of electromagnetic wave would be used for the following applications:

Sun tanning; Television remote; Medical imaging

17. (HT) Explain why radio waves are suitable for transmitting TV images to the home.

Lenses (physics only) – QuestionIT

18.

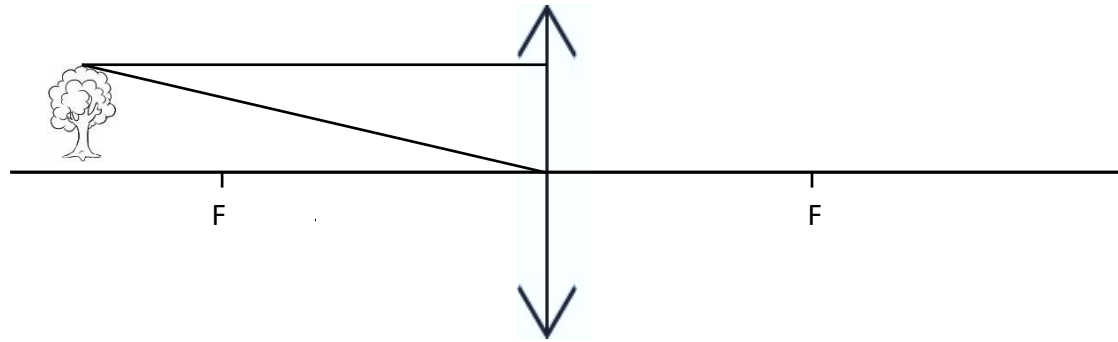

- Copy and complete the two light rays on the diagram.
- Label the principle axis, object and focal length on the diagram.
- Describe the image produced by the above lens.

19. A 12cm object viewed in a convex lens has an image size of 54cm. Calculate the magnification of the lens.

Visible light (physics only) – QuestionIT

20. Describe the difference between a transparent and a translucent object.
21. A vase is illuminated with green and blue light. What colour would the vase appear if viewed through a red filter?
22. Which colour of light has the shortest wavelength?
23. Copy and complete the ray diagrams.

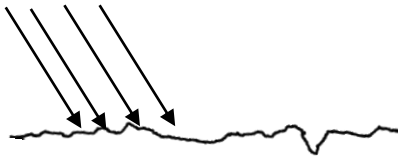

White light

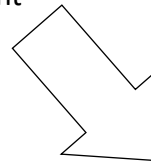

Green vegetable

AnswerIT!

Electromagnetic Waves

- Types of electromagnetic waves
- Properties of electromagnetic waves
- Uses and applications of electromagnetic waves
- Lenses (physics only)
- Visible light (physics only)



Electromagnetic waves – QuestionIT

1. What type of waves are electromagnetic waves?

Transverse.

2. List the main electromagnetic waves in order from lowest to highest frequency.

Radio microwave infrared visible ultraviolet X ray gamma ray

3. Which of the following is the speed of electromagnetic waves in a vacuum?

300 m/s

300 000m/s

300 000 000m/s

4. Which colour of light has the longest wavelength?

Red.

5. Describe one piece of evidence to show that light waves do not need a medium to travel from one place to another.

Light waves travel through space which is a vacuum.

Properties of electromagnetic waves – QuestionIT

6. The four surfaces below are heated equally with infrared (IR) heat.

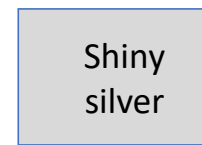
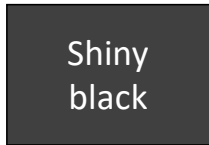

a. Which surface will absorb the most IR radiation? **Matt black.**

b. Which surface will reflect the most IR radiation? **Shiny silver.**

7. The diagrams show three waves travelling from air into different materials.

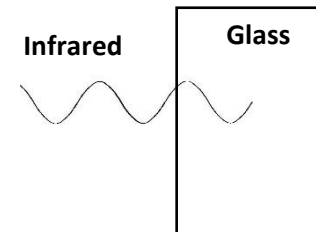
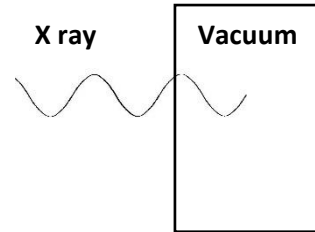
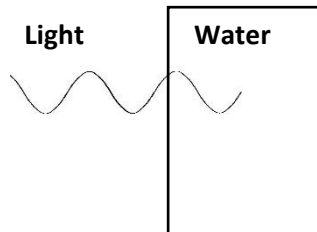

Which wave will be travelling the slowest? **Glass.**

Properties of electromagnetic waves – QuestionIT

8. The light wave shown below meets a boundary between glass and air. Continue the light ray to show its path after passing the boundary.

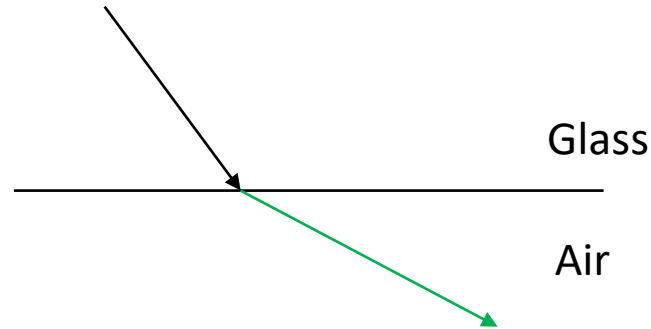

9. (HT) The wave front below is travelling from air into water. Explain why the wave front bends.

Left side of wave meets the denser material first.
The left side will slow down before the right side.
This will cause the wave to bend.

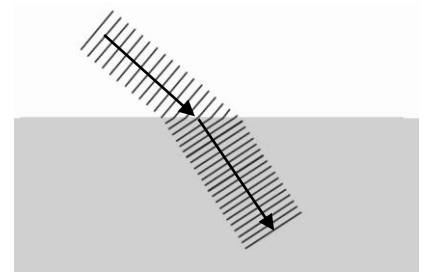

10. Infrared rays strike a black tile. Will the waves mainly be reflected, refracted or absorbed? **Absorbed.**

Properties of electromagnetic waves – QuestionIT

11. (HT) Radio waves are transmitted through the air and received by aerials.

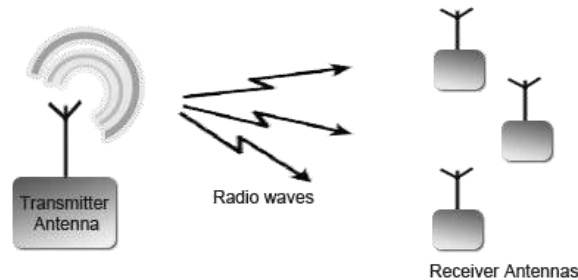

- a. How are radio waves produced in the transmitter aerial?

Produced by oscillations (vibrations) in a wire or electrical circuit.

- b. What is produced in the receiving antenna when radio waves are absorbed?

An alternating current of the same frequency as the radio wave.

12. Most electromagnetic waves are produced from energy changes in electron levels. How does gamma wave production differ from this?

Gamma waves are emitted from changes in the nucleus of an atom.

Properties of electromagnetic waves – QuestionIT

13. Which three types of electromagnetic waves can cause damage to cells in the body?

Gamma waves, X rays and Ultraviolet.

14. What is meant by radiation dose?

A measure of the risk of harm from exposure to radiation.

15. The chart shows the average radiation dose a UK person is exposed to in a year.

a) What percentage of the radiation dose comes from natural sources?

70 – 80%

b) Give **two** reasons why a person could receive a higher dose of background radiation.

Receive increased medical diagnosis

Live in a higher radon area.

Increased cosmic rays from flying.

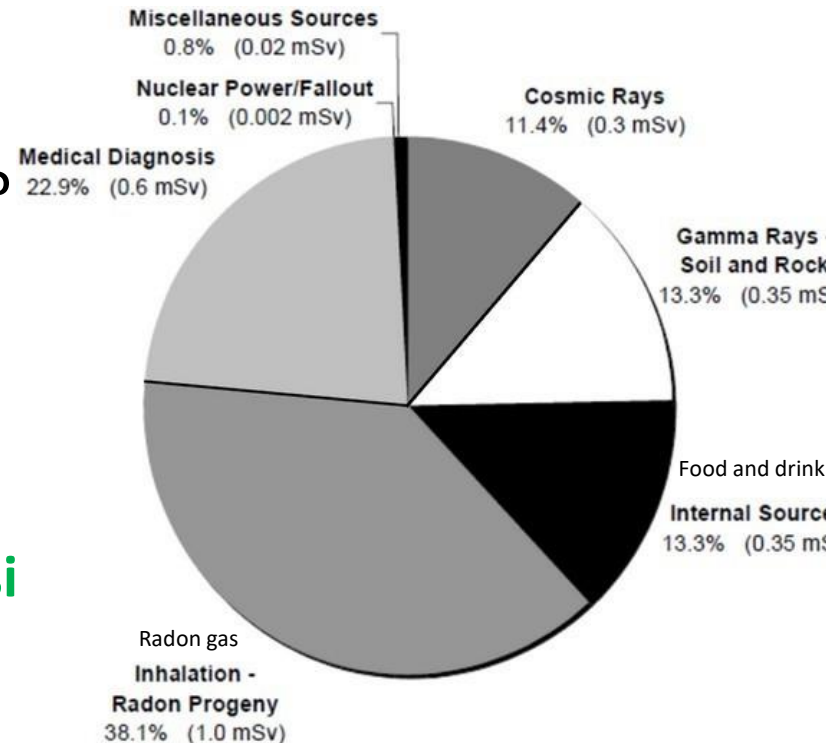

Uses of electromagnetic waves – QuestionIT

16. State which type of electromagnetic wave would be used for the following applications:

Sun tanning; Television remote; Medical imaging

Ultraviolet

Infrared

X rays or gamma rays

17. (HT) Explain why radio waves are suitable for transmitting TV images to the home.

Travel long distances through the atmosphere.

Lenses (physics only) – QuestionIT

18.

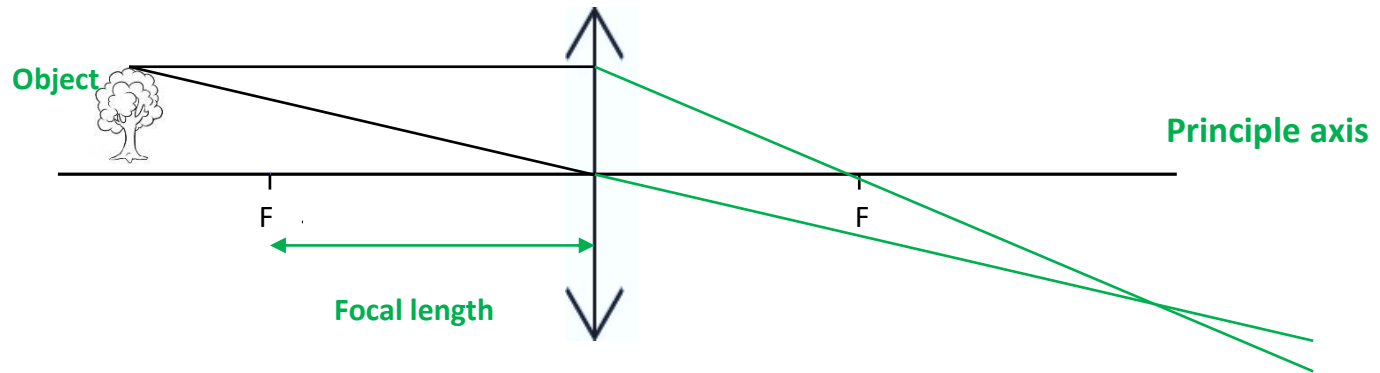

- Copy and complete the two light rays on the diagram.
- Label the principle axis, object and focal length on the diagram.
- Describe the image produced by the above lens.

Inverted, laterally inverted, magnified, real

19. A 12cm object viewed in a convex lens has an image size of 54cm. Calculate the magnification of the lens.

$$\text{Magnification} = \text{image height/object height} = 54/12 = \text{x}4.5$$

Visible light (physics only) – AnswerIT

20. Describe the difference between a transparent and a translucent object.

Transparent- the object can be seen clearly.

Translucent- object can be partially seen through it.

21. A vase is illuminated with green and blue light. What colour would the vase appear if viewed through a red filter?

No colour (black).

22. Which colour of light has the shortest wavelength?

Violet

23. Copy and complete the ray diagrams .

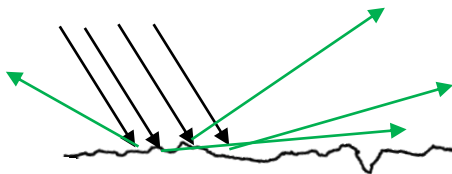

White light

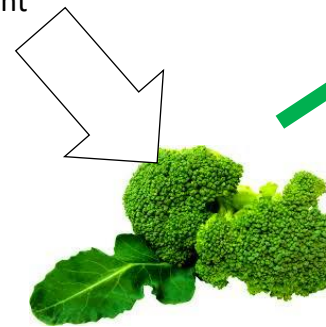

Green vegetable

Green only
reflected

LearnIT! KnowIT!

Black body radiation (physics only)

- Emission and absorption of infrared radiation
- Perfect black bodies and radiation



Black body radiation (physics only)

All objects (bodies) absorb and reflect infrared radiation. The hotter the object is, the more infrared radiation it emits.

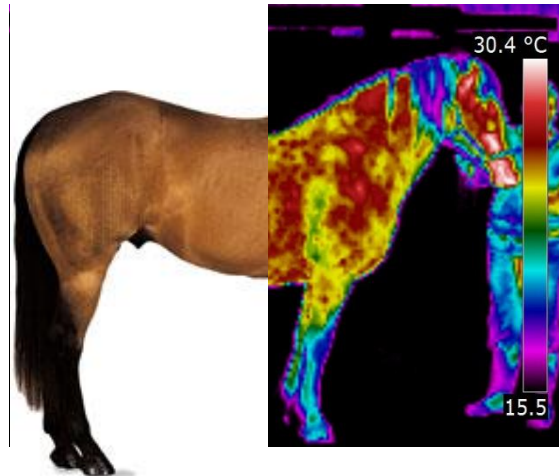

An infrared detecting camera is needed to “see” the heat radiated by the horse

The horse absorbs infrared heat from the sun and then re-radiates this heat, sometimes at a different wavelength.

The **intensity and wavelength** of energy radiated by the horse depends on its **temperature**.

If the horse is to remain at a constant temperature, it must radiate infrared heat energy at the same rate as it absorbs it. If the horse can not emit radiation as quickly as it is absorbed, its temperature will increase.

Black body radiation (physics only)

A **perfect black body** is an object that **absorbs all of the radiation** incident on it. It **does not reflect or transmit any radiation**. Since a good absorber is a good emitter, a **perfect black body** would be the **best possible emitter**.

All bodies emit radiation. The intensity and wavelength distribution of any emission depends on the temperature of the body.

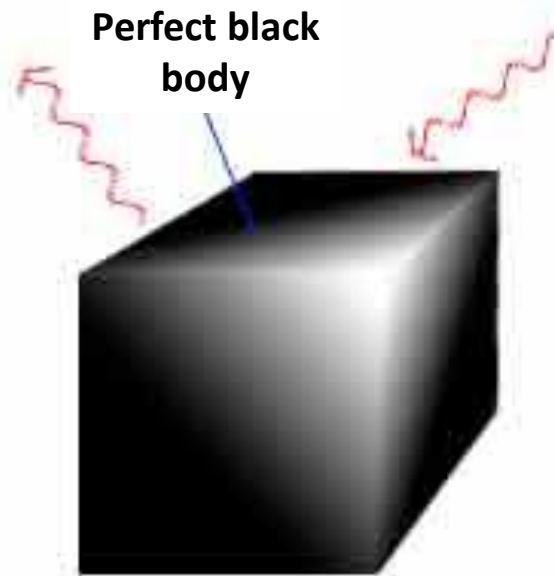

Higher: Temperature

A body at a constant temperature is absorbing radiation at the same rate as it is emitting radiation. The temperature of a body increases when the body absorbs radiation faster than it emits radiation.

The temperature of a body is related to the balance between incoming radiation absorbed and radiation emitted.

Black body radiation (physics only)

The Earth behaves in a similar way to a black body.

Wavelengths of electromagnetic energy from the sun including **ultraviolet, visible light and infrared**, penetrate the **Earth's atmosphere** and heat up the surface of the Earth.

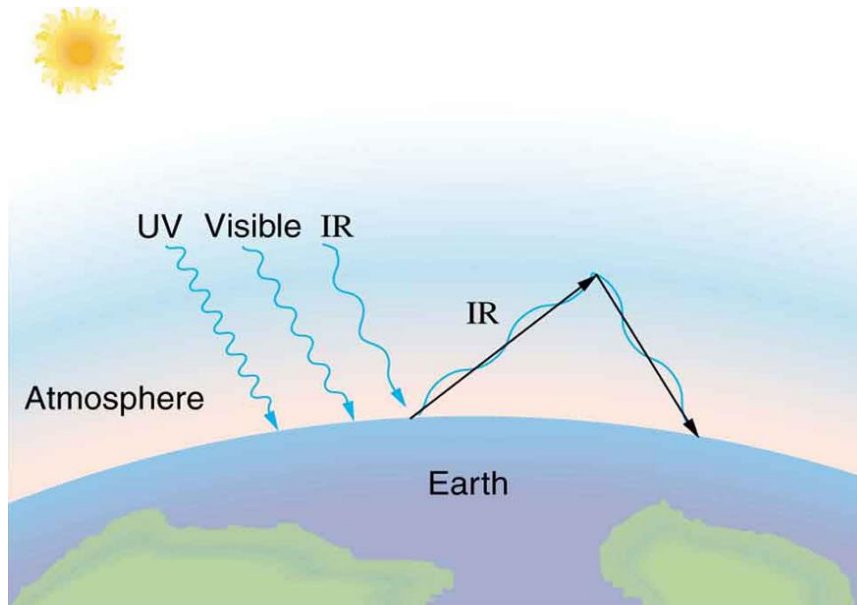

As the Earth heats up, it radiates infrared waves at a **longer wavelength** than those entering the atmosphere.

These longer wavelength infrared waves are **reflected back to Earth** by the upper atmosphere.

This prevents energy from being lost at the same rate as energy is received resulting in the Earth's temperature increasing. This is known as **global warming**.

Increased **carbon dioxide** in the atmosphere (from burning fuels) reduces the amount of radiation leaving the Earth. This results in a warming of the atmosphere (**global warming**). Snow and ice reflect incoming radiation. Global warming melts snow and ice resulting in further global warming.

QuestionIT!

Black body radiation (physics only)

- Emission and absorption of infrared radiation
- Perfect black bodies and radiation



Black body radiation (physics only) – QuestionIT

1. A black body is
 - a. an object that emits no electromagnetic radiation.
 - b. an object that absorbs all electromagnetic radiation that falls on it.
 - c. an object that only emits invisible electromagnetic radiation.
 - d. an object that absorbs all electromagnetic radiation that falls on it and emits no electromagnetic radiation.
2. Explain how black body radiation differs from reflected radiation.
3. The picture shows a thermal image of a cat. Why can we not see this thermal emission from the cat without using a specialised camera?



Black body radiation (physics only) (HT) – QuestionIT

4. The stone is in the sunshine and emitting radiation.

As the stone heats up through the day, how will the nature of the emitted radiation change?



5. If a body absorbs radiation at a faster rate than it emits radiation, what change will happen to the body?

6. The diagram shows how global warming of the Earth can occur. Explain what is happening in terms of changes to absorbed and emitted radiation.

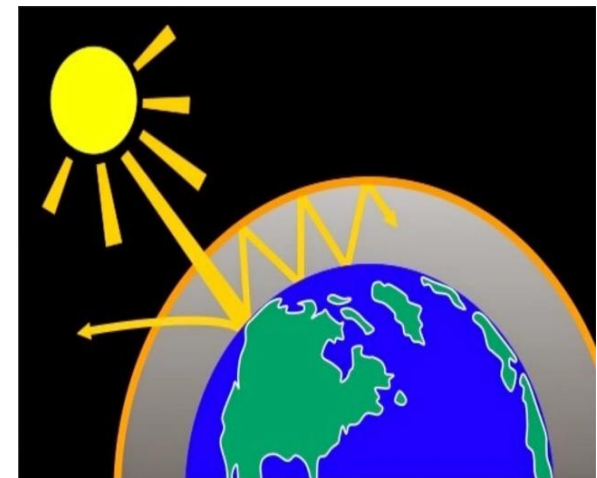

AnswerIT!

Black body radiation (physics only)

- Emission and absorption of infrared radiation
- Perfect black bodies and radiation



Black body radiation – AnswerIT

1. A black body is
 - a. an object that emits no electromagnetic radiation.
 - b. an object that absorbs all electromagnetic radiation that falls on it.**
 - c. an object that only emits invisible electromagnetic radiation.
 - d. an object that absorbs all electromagnetic radiation that falls on it and emits no electromagnetic radiation.
2. Explain how black body radiation differs from reflected radiation.
Black body radiation is radiation that is absorbed by an object and then re-radiated out, sometimes as a different wavelength.

3. The picture shows a thermal image of a cat.
Why can we not see this thermal emission from the cat without using a specialised camera?

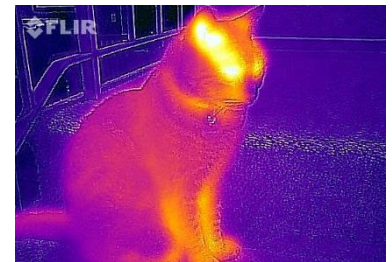

The radiation is in the infrared range which humans can not see.

Black body radiation (HT) – AnswerIT

4. The stone is in the sunshine and emitting radiation. As the stone heats up through the day, how will the nature of the emitted radiation change?

It will be more intense and of a higher frequency.



5. If a body absorbs radiation at a faster rate than it emits radiation, what change will happen to the body?

The body will increase in temperature.

6. The diagram shows how global warming of the Earth can occur. Explain what is happening in terms of changes to absorbed and emitted radiation.

Radiation that can pass through the atmosphere reaches the Earth. This radiation will heat up the Earth's surface. The Earth will radiate infrared energy back out but at a wavelength that can not penetrate the atmosphere.

The Earth will warm up as more radiation is being absorbed than emitted.

