

# Overview – AQA Physics Paper 1 – Unit 2 Electricity

## Current, Potential Difference and Resistance

- Standard circuit diagram symbols
- Electrical charge and current
- Current, resistance and potential difference
- Resistors

## Series and Parallel Circuits

## Domestic Uses and Safety

- Direct and alternating potential difference
- Mains electricity

## Energy Transfers

- Power
- Energy transfers in everyday appliances
- The National Grid

## Static Electricity (Physics Only)

- Static charge
- Electric fields

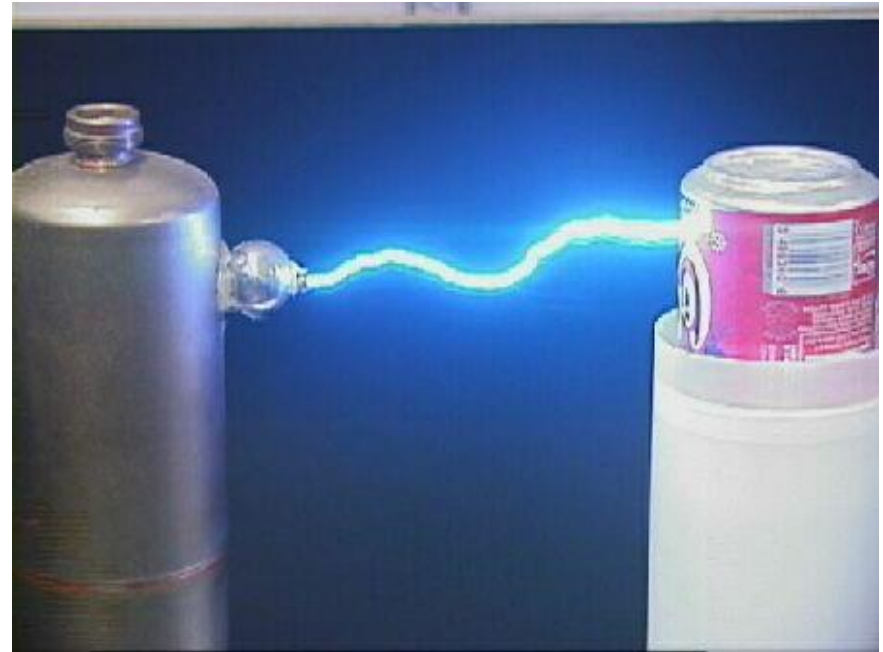



# Standard Circuit Diagram Symbols

## Circuit Symbols

**Circuit symbols** are used to clearly show components in a circuit and how they are connected.

These circuit symbols must be **learnt** so that you can draw them and **interpret circuit diagrams** that use them.

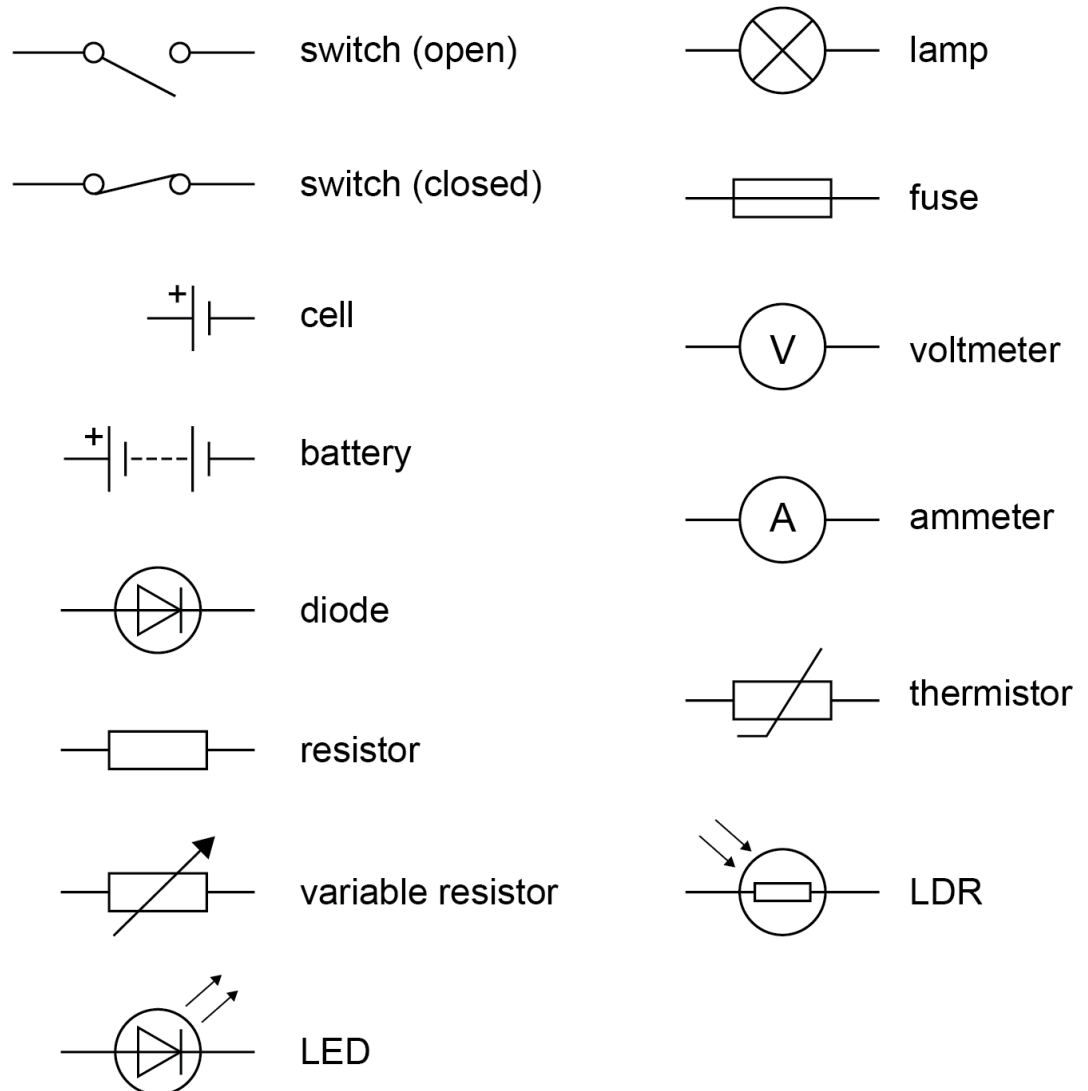

# Terminology

Term	Definition
Current	The rate of flow of charge in a circuit.
Potential Difference	Also called voltage. The difference in potential between two points of a circuit. Causes a current to flow.
Charge	Charge is the amount of electricity travelling through a circuit.
Resistance	Anything that slows the flow of charge around a circuit. Resistance is usually caused by electrons colliding with ions in a material.
Series Circuit	A circuit with a single loop of wire.
Parallel Circuit	A circuit with two or more loops (branches) of wire.

# Electrical charge and current

For electrical charge to flow through a closed circuit, the circuit must include a source of potential difference.

An **electric current** is the **flow of electrical charge**, usually **electrons**, around a circuit. The size of the electric current is the rate of flow of electrical charge. In a **series circuit** (one with a single loop of wire) the current is the same at any point of the loop.

Charge flow, current and time are linked by the equation:

*Intensité de courant*

*'I' symbol used by*

André-Marie Ampère

**Charge flow (C) = Current (A) × Time (s)**

$$Q = I t$$

Name	Equation symbol	Unit	Unit Symbol
Charge flow	Q	Coulombs	C
Current	I	Amp	A
Time	t	Seconds	s

## Example

A current of 1.2 A flows through a wire for 5 minutes.

Work out the charge that has moved in the wire in the 5 minutes.

## Solution

Convert time into standard units: 5 minutes = 300 seconds

State equation:  $Q = I t$

Substitution:  $Q = 1.2 \times 300$

Answer:  $Q = 360 \text{ C}$

# Current, Resistance and Potential Difference

- The **current** ( $I$ ) through a component depends on both the **resistance** ( $R$ ) of the component and the **potential difference** ( $V$ ) across the component.
- The **greater the resistance** of the component, the **smaller the current** for a **given potential difference** ( $V$ ) across the component.

Current, potential difference or resistance can be calculated using the equation:

**Potential Difference ( $V$ ) = Current ( $A$ ) x Resistance ( $\Omega$ )**

$$V = I R$$

The resistance in a circuit will depend on the components used in the circuit as well as the length of wire used in the circuit. The longer the wire, the greater the resistance.

Name	Equation symbol	Unit	Unit Symbol
Potential difference	V	Volts	V
Current	I	Amp	A
Resistance	R	Ohms	$\Omega$

# Current, Resistance and Potential Difference

## Example

A resistor is placed into the circuit shown.  
The meter readings are shown next to  
each meter.

Work out the resistance.

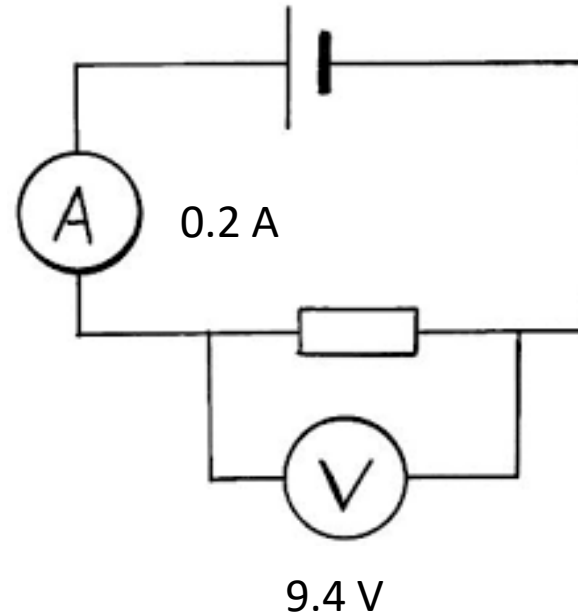

## Solution

State the equation:  $V = I \times R$

Rearrange:  $R = V / I$

Substitution:  $R = 9.4 / 0.2$

Answer:  $R = 47 \Omega$



# Ohmic Conductors

Some resistors have a fixed value that does not depend on the current flowing through the circuit. **These are ohmic conductors.**

Ohm's Law states "the current through an ohmic conductor (at a constant temperature) is **directly proportional** to the potential difference across the resistor".

Ohmic conductors will produce a **straight line**  $I - V$  graph that goes through the origin.

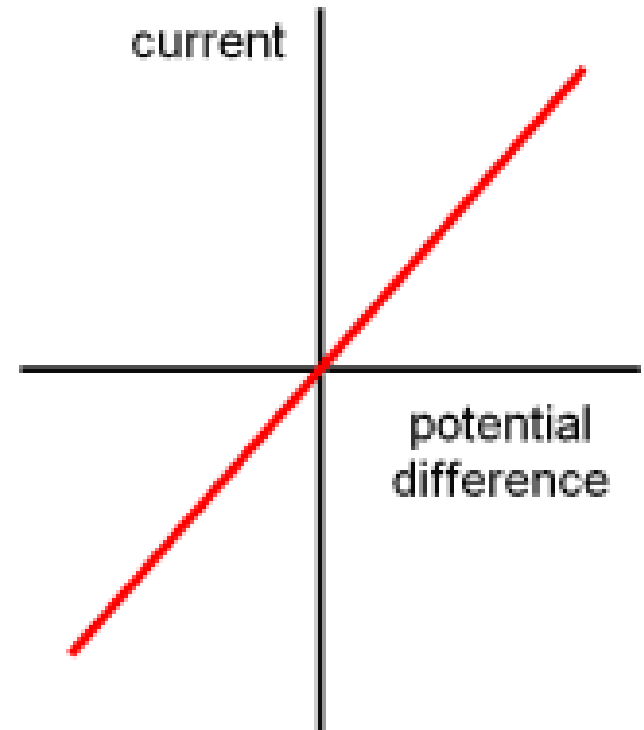

# Non-Ohmic Conductors: Filament Lamp

The resistance of components such as lamps, diodes, thermistors and LDRs is not constant. It changes with the current through the component.

A filament lamp is often called a lamp or a lightbulb.

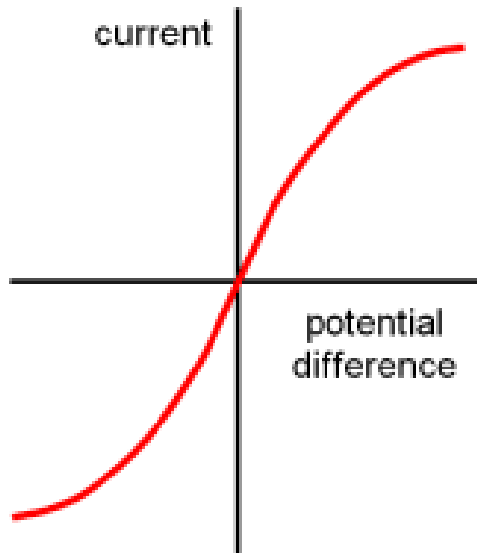

As the **current increases**, the **temperature** of filament increases therefore the **resistance** of the filament lamp **increases**.

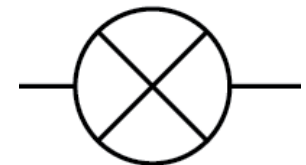
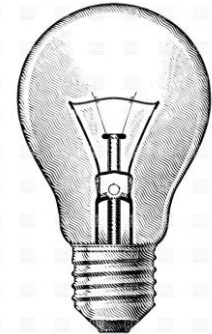

# Non-Ohmic Conductors: Diodes

**Diodes** are electrical components that only allow a **current to flow in one direction** only.

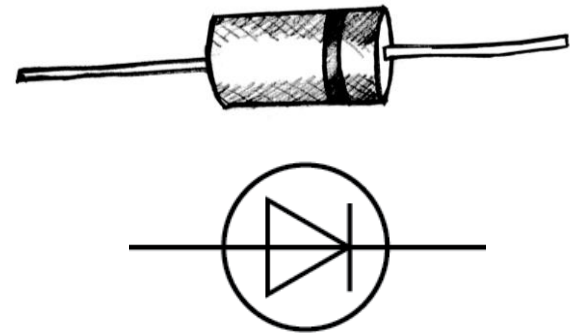
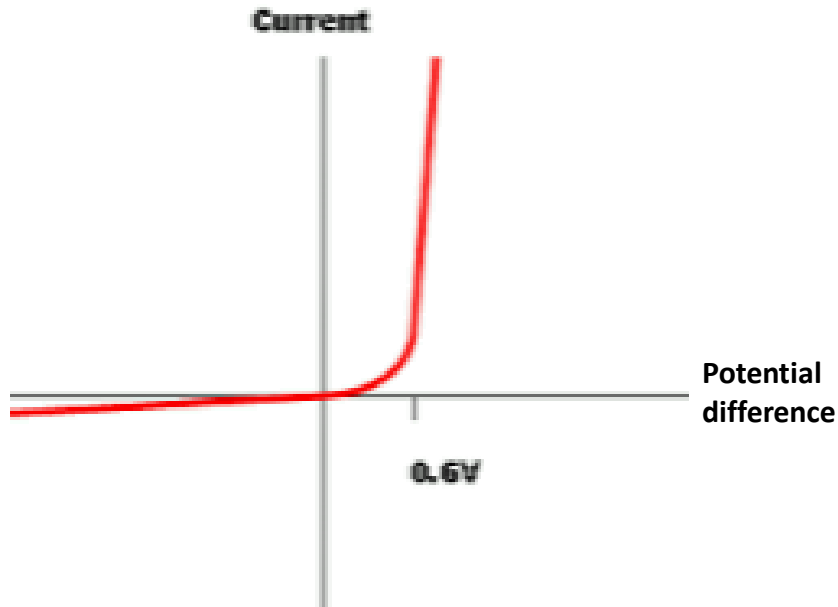

Diodes have a **low resistance** in the **forward** direction but a **high resistance** in the **reverse** direction.

# Thermistors and LDRs

**Thermistors** are types of resistors where the resistance varies with **temperature**.

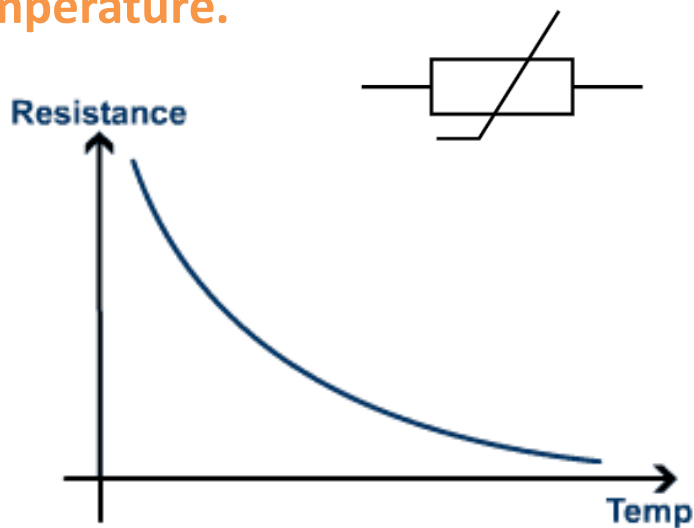

The resistance of a thermistor decreases as temperature increases.

Thermistors are used in thermostats to control temperature in the home.

**Light Dependent Resistors - LDRs** are types of resistors where the resistance varies with **light intensity**.

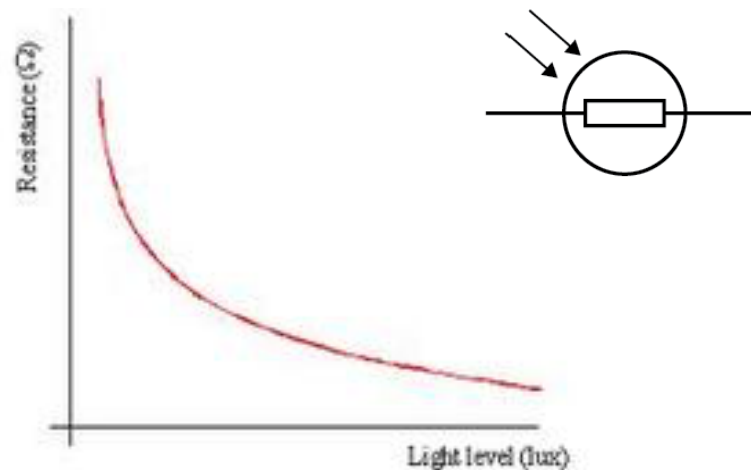

The resistance of a LDR decreases as light intensity increases.

LDRs are used as switches to turn on street lights when it gets dark.

## Measuring Resistance:

To measure the resistance of an electrical component the following circuit needs to be set up...

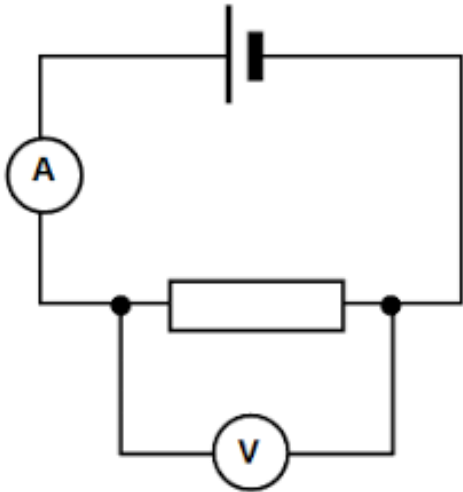

By measuring the **current**, using the **ammeter**, and the **potential difference**, using a **voltmeter**, the **resistance** can be found from...

$$R = \frac{V}{I}$$

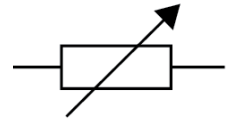

The electrical component tested can be changed from the resistor shown to any other electrical component.

To get a **range of potential differences** and currents a **variable resistor** can be added into the circuit **or** the input potential difference changed.

Name	Equation symbol	Unit	Unit Symbol
Potential difference	V	Volts	V
Current	I	Amp	A
Resistance	R	Ohms	$\Omega$

# QuestionIT!

## Current, Potential Difference and Resistance

- Standard circuit diagram symbols
- Electrical charge and current
- Current, resistance and potential difference
- Resistors



# Current, Potential Difference and Resistance - QuestionIT

- 1. Draw the circuit symbols for the following components...**
  - a. A switch open and a switch closed
  - b. A cell
  - c. A battery
  - d. A diode
  - e. A resistor
  - f. A variable resistor
  - g. An LED (light emitting diode)
  - h. A lamp
  - i. A fuse
  - j. A voltmeter
  - k. An ammeter
  - l. A thermistor
  - m. An LDR (light dependent resistor)
- 2. Describe the difference between a series circuit and a parallel circuit.**
- 3. What is an electric current?**

# Current, Potential Difference and Resistance – QuestionIT

4. State the equation that links charge flow, current and time.
5. Calculate the current in a circuit if a charge of 4 C flows in 20 seconds.
6. In a lightning bolt, a charge of 15 C flows and there is a current of 30,000 A.  
Calculate the duration of the lightning strike.
7. What is an ohmic conductor?
8. Which of the following current – potential difference graphs is for an ohmic conductor? Explain your answer.

A resistor at constant temperature

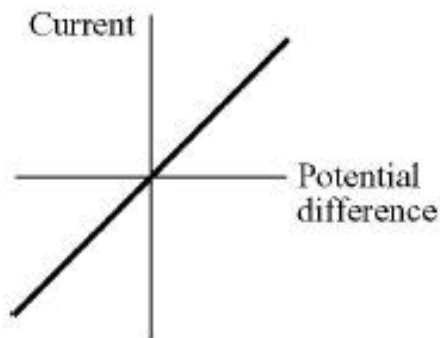

A filament lamp

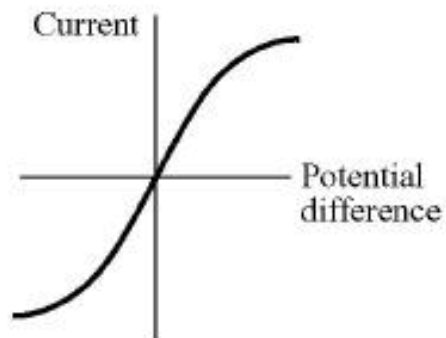

A diode

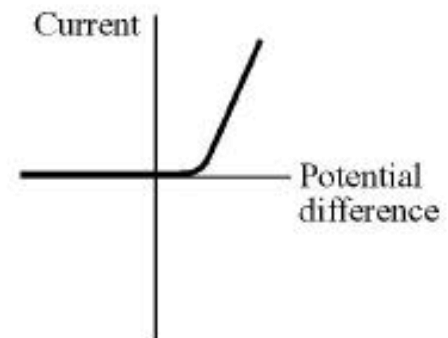



## Current, Potential Difference and Resistance – QuestionIT

9a) A student wants to draw a current – potential difference graph for a filament lamp.

Draw a circuit that the student will need to set up to obtain the data needed to be able to draw the graph.

9b) Sketch the current– potential difference graph the student should obtain and say why the graph has the shape you have drawn.

# AnswerIT!







## Current, Potential Difference and Resistance

- Standard circuit diagram symbols
- Electrical charge and current
- Current, resistance and potential difference
- Resistors

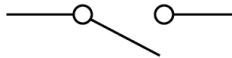

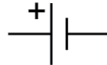
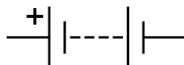
# Current, Potential Difference and Resistance – AnswerIT

## 1. Draw the circuit symbols for the following components...

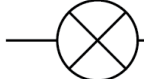
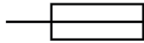
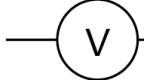
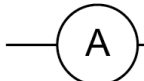
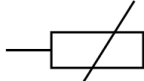
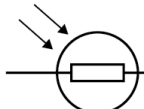
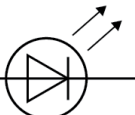
- a.**  switch (open)
- b.**  switch (closed)
- c.**  cell
- d.**  battery
- e.**  diode
- f.**  resistor
- g.**  variable resistor
- h.**  lamp
- i.**  fuse
- j.**  voltmeter
- k.**  ammeter
- l.**  thermistor
- m.**  LDR
- g.**  LED

# Current, Potential Difference and Resistance - AnswerIT

2. Describe the difference between a series circuit and a parallel circuit.

- A series circuit contains only one loop of wire.
- A parallel circuit contains two or more loops (branches) of wire.

3. What is an electric current?

- An electric current is the flow of charge, usually electrons.

4. State the equation that links charge flow, current and time.

$$Q = I t$$

5. Calculate the current in a circuit if a charge of 4 C flows in 20 seconds.

- $Q = I t$
- $I = Q / t$       or       $I = 4 / 20$
- $I = 0.2 \text{ A}$

6. In a lightning bolt, a charge of 15 C flows and there is a current of 30,000 A.  
Calculate the duration of the lightning strike.

- $t = Q / I$
- $t = 15 / 30\ 000$
- $t = 0.0005 \text{ s}$     or     $0.5 \text{ ms}$

# Current, Potential Difference and Resistance - AnswerIT

7. What is an ohmic conductor?

- A material where the current through the material is proportional to the potential difference applied across its ends.

8. Which of the following current – potential difference graphs is for an ohmic conductor? Explain your answer.

A resistor at constant temperature

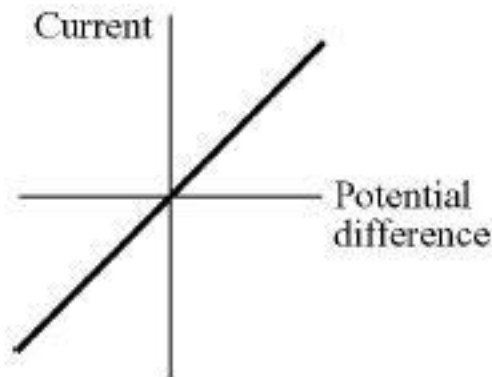

A filament lamp

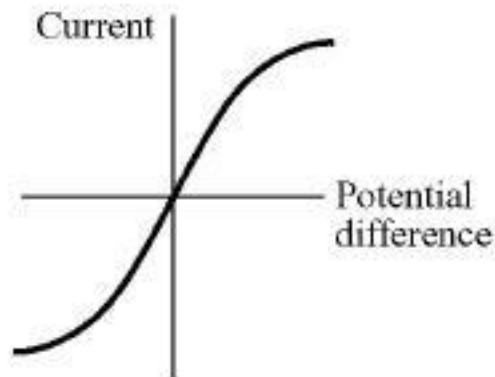

A diode

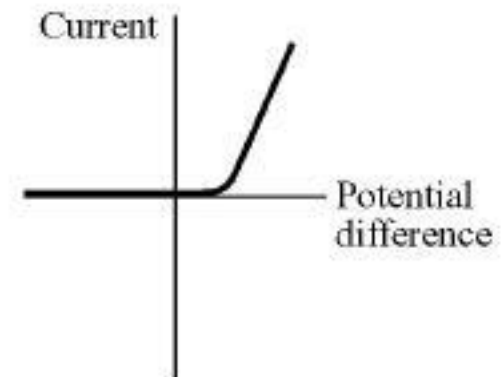

- The resistor is the ohmic conductor, as the graph produced is a straight line through the origin.

# Current, Potential Difference and Resistance – AnswerIT

9a) A student wants to draw a current – potential difference graph for a filament lamp.

Draw a circuit that the student will need to set up to obtain the data needed to be able to draw the graph.

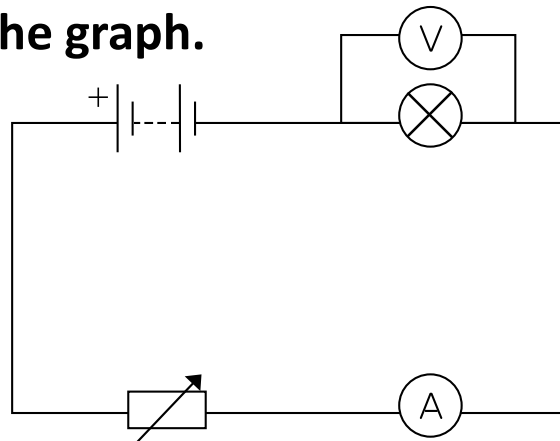

9b) Draw the current– potential difference graph the student should obtain and explain why the graph has the shape you have drawn.

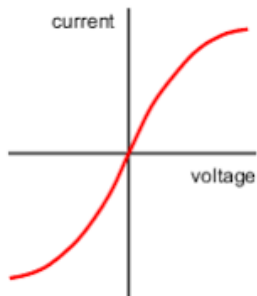

- As the current increases the temperature of the filament increases thus increasing the resistance of the filament lamp.

# LearnIT! KnowIT!

## Series and Parallel Circuits



## Parallel Circuits

Parallel Circuits consist of **two or more loops** (branches) of wire.

For components connected in parallel:

- the **potential difference** across each **component is the same**
- the total current through the whole circuit is the **sum** of the currents through the separate components on each loop (branch)
- the **total** resistance of **two resistors** is less than the **resistance** of the **smallest** individual **resistor**.

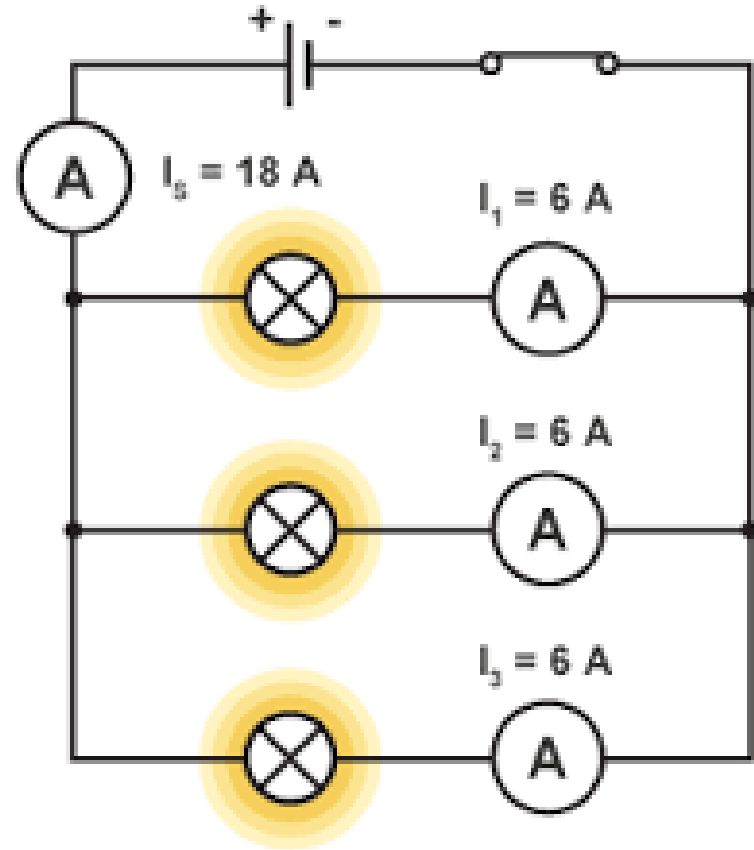



## Series Circuits

Series circuits consist of **one loop of wire**.

For components connected in series:

- there is the **same current** through each component
- the **total potential difference** of the power supply is **shared** between the components
- the **total resistance of two** components is the sum of the **resistance** of each component.

$$R_{\text{total}} = R_1 + R_2$$

resistance,  $R$ , in ohms,  $\Omega$

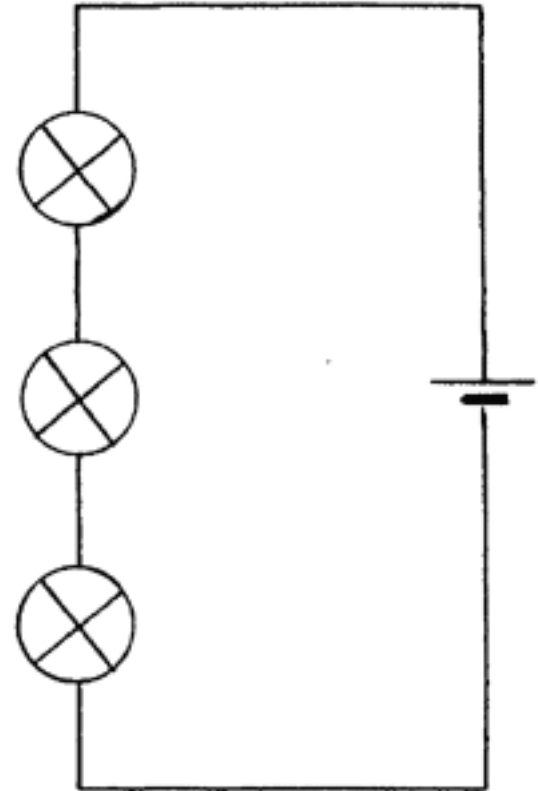

# QuestionIT!

## Series and Parallel Circuits



# Series and Parallel Circuits - Question 1

1. Describe how the currents in a series circuit and a parallel circuit differ.
2. Draw a fully labelled series circuit that contains a switch, a battery and two lamps.
3. Calculate the resistance of the resistors in series shown in the diagram below.

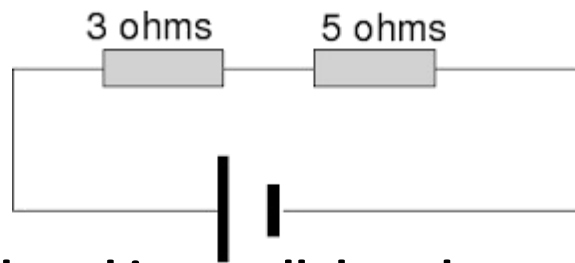

4. Two resistors are placed in parallel as shown in the diagram below.  
What will the maximum resistance of the circuit be?

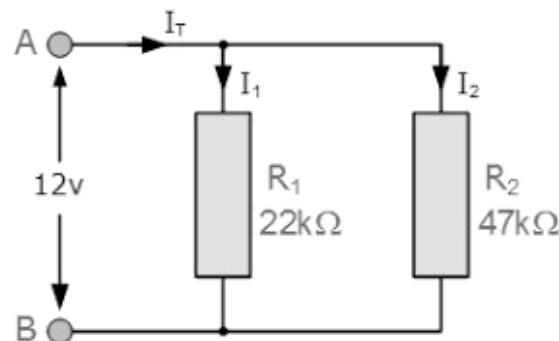

## Series and Parallel Circuits - Question 1

5a) What is the current in the main branch ( $I_s$ ) of the circuit shown?

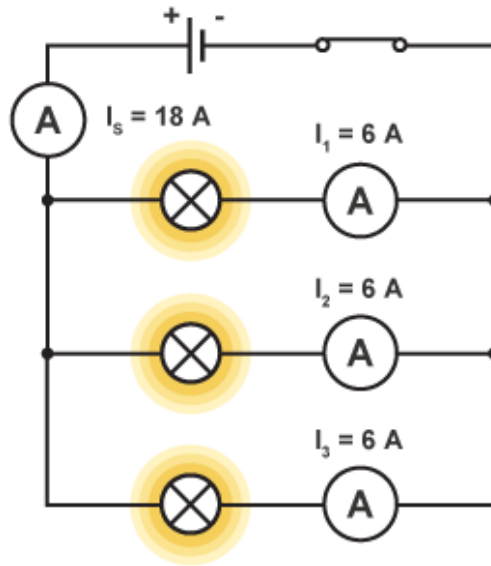

5b) The cell in the circuit above supplies a potential difference of 9 V to the circuit.

What is the potential difference across each lamp?

Explain your answer.

# AnswerIT!

## Series and Parallel Circuits



## Series and Parallel Circuits - AnswerIT

1. Describe how the currents in a series circuit and a parallel circuit differ.
  - Series circuit – same current at any point of the loop.
  - Parallel circuit – the total current through the whole circuit is the sum of the currents in each loop.
2. Draw a fully labelled series circuit that contains a switch, a battery and two lamps.

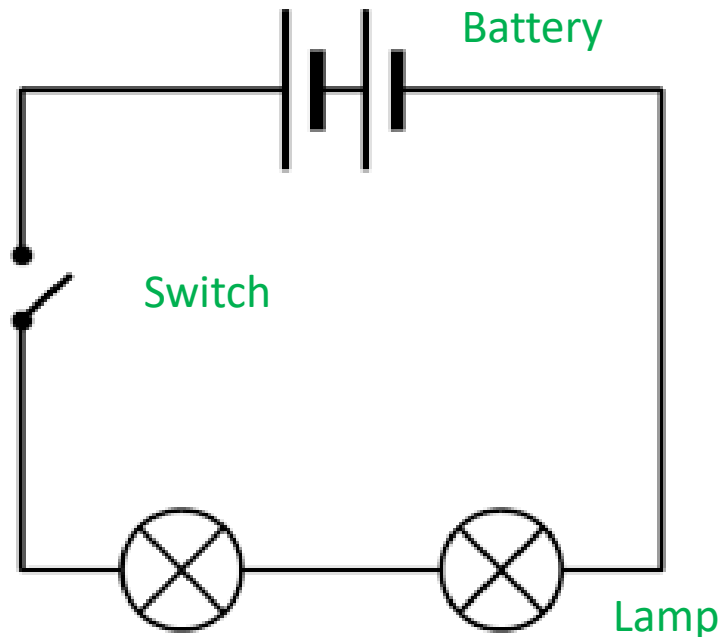

## Series and Parallel Circuits - AnswerIT

3. Calculate the resistance of the resistors in series shown in the diagram below.

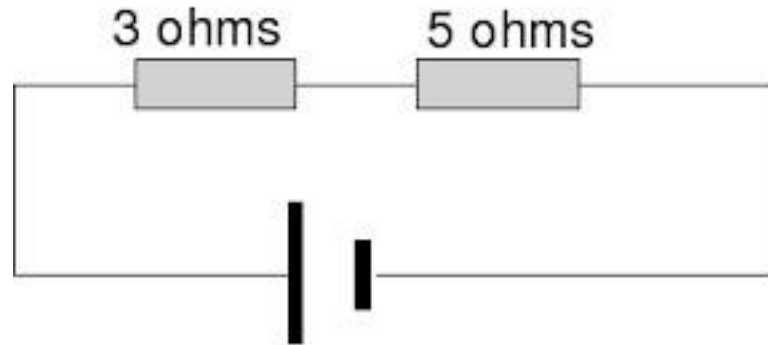

- $R_{\text{total}} = R_1 + R_2$
- $8 \Omega$

4. Two resistors are placed in parallel as shown in the diagram below. Why will the maximum resistance of the circuit be less than  $22 \text{ k}\Omega$ ?

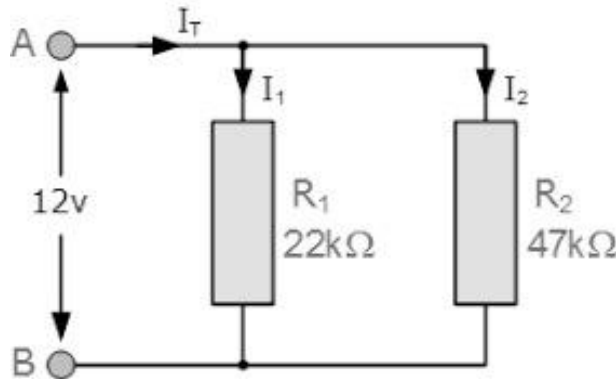

- It will be less than  $22 \text{ k}\Omega$  because the total resistance of two resistors in parallel is less than the resistance of the smallest individual resistor.
- The smallest individual resistor is  $22 \text{ k}\Omega$ .

## Series and Parallel Circuits - AnswerIT

5a) What is the current in the main branch ( $I_s$ ) of the circuit shown?

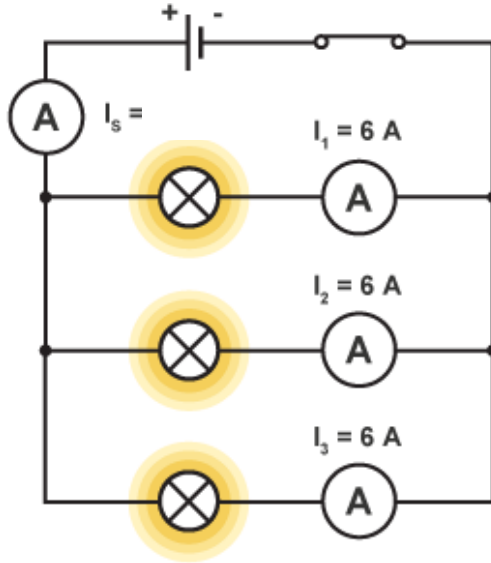

- 18 A
- As  $6 + 6 + 6 = 18$

5b) The cell in the circuit above supplies a potential difference of 9 V to the circuit.

What is the potential difference across each lamp? Explain your answer.

- 9 V
- As the potential difference across each lamp is the same in a parallel circuit.



# LearnIT!

# KnowIT!

## Domestic Uses and Safety

- Direct and alternating potential difference
- Mains electricity



# Direct and Alternating Potential Difference

## Direct and Alternating Potential Difference

A **direct potential difference** will produce a **direct current (dc)** (a current in which the charge carriers move in one direction only). **Batteries are dc.**

An **alternating potential difference** will produce an **alternating current (ac)** (a current in which the charge carriers move backwards and forwards).

**Mains electricity is ac.**

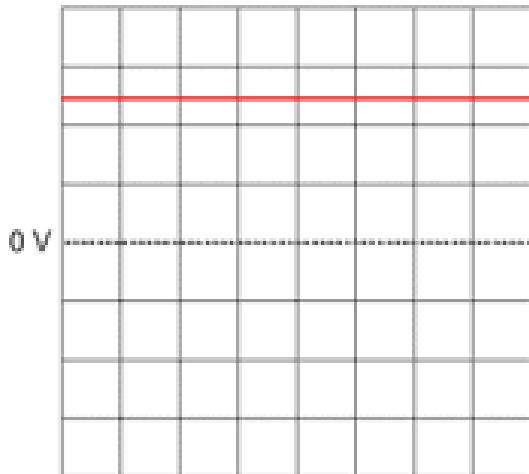

**A direct pd does not go below 0 V**

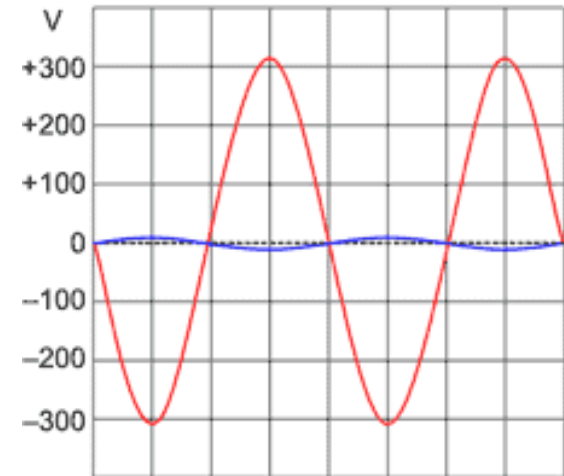

**An alternating pd goes below 0 V**

## Mains Electricity Supply

In the UK, mains electricity is supplied at approximately 230 V, 50 Hz ac.

- The mains supply does change slightly, which is why your lights at home may get a bit brighter or dimmer at various times.
- Lights usually dim when a commercial starts on TV during a big show, as lots of people get up to put the kettle on and so demand increases.

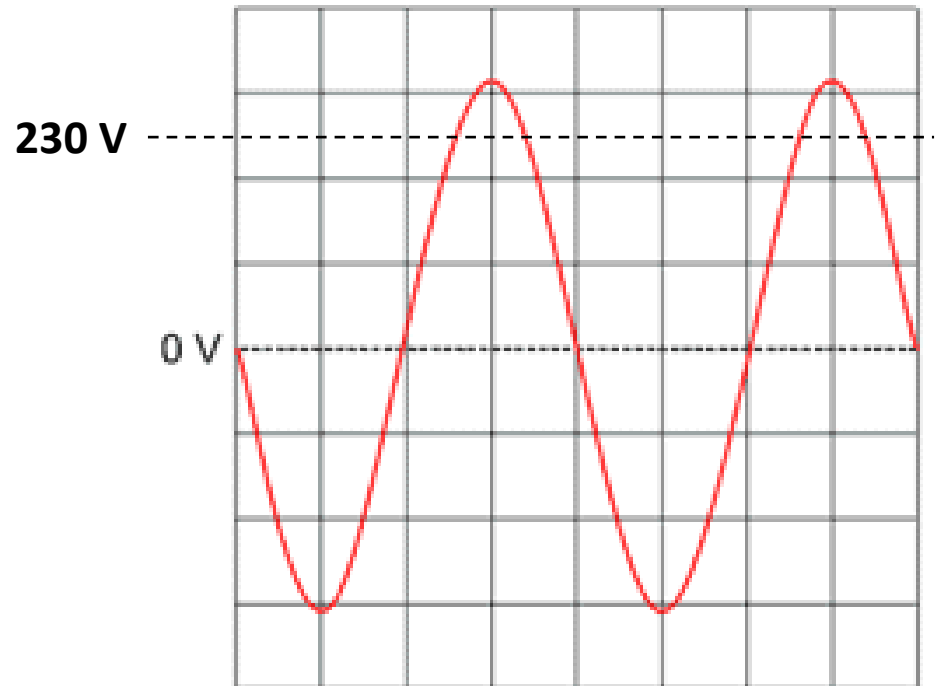

## Wiring in the Home

**Most electrical appliances are connected to the mains using three-core electrical cable.**

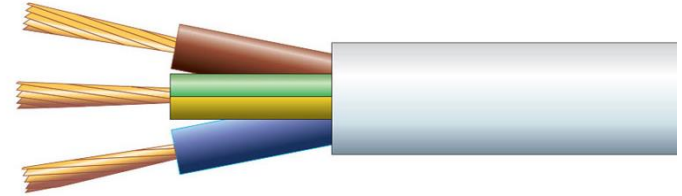

Name	Colour	Function
Live	Brown	Carries alternating potential difference from the supply.
Neutral	Blue	Completes the circuit.
Earth	Yellow/Green	Safety wire to stop appliance becoming live.

## Wiring in the Home... continued

- The potential difference between the live wire and earth (0 V) is about **230 V**.
- The neutral wire is at, or close to, earth potential (0 V).
- The earth wire is at 0 V,
- The earth wire **only** carries a **current** if there is a **fault**.

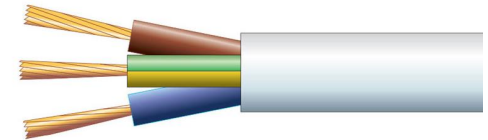

The live wire may be dangerous when a switch in the mains circuit is open as a person could complete the circuit to ground (0 V) themselves and therefore get **electrocuted** as the current will flow through them.

**Any** connection between the live wire and earth can cause a current to flow. This can **potentially** cause:

- **electrical fires**, if the current is too high
- or **electrocution**, if a person is making the connection.



# QuestionIT!

## Domestic Uses and Safety

- Direct and alternating potential difference
- Mains electricity



# Domestic Uses and Safety - QuestionIT

1. What does a.c stand for?
2. What does d.c stand for?
3. Give an example of where a.c is used.
4. Give an example of where d.c is used.
5. Describe the difference between alternating potential difference and direct potential difference. You may draw a sketch graph to help answer the question.
6. What is the frequency and potential difference of mains electricity in the U.K?
7. Copy and complete the table below for the wire in three core electrical cable.

Name	Colour	Function

8. Explain why a live wire may be dangerous even when a switch in the mains circuit is open.

# AnswerIT!

## Domestic Uses and Safety

- Direct and alternating potential difference
- Mains electricity





# Domestic Uses and Safety - AnswerIT

1. What does a.c stand for?

**Alternating current**

2. What does d.c stand for?

**Direct current**

3. Give an example of where a.c is used.

**Mains electricity**

4. Give an example of where d.c is used.

**Batteries**

5. Describe the difference between an alternating potential difference and direct potential difference. You may draw a sketch graph to help answer the question.

- **An alternating potential difference will go from positive to negative repeatedly**
- **Producing an alternating current in a circuit.**
- **A direct potential difference will stay either positive or negative, but not change sign**
- **Producing a direct current in a circuit.**

# Domestic Uses and Safety - AnswerIT

6. What is the frequency and potential difference of mains electricity in the U.K?

Frequency 50Hz

Potential difference 230V

7. Copy and complete the table below for the wire in three core electrical cable.

Name	Colour	Function
Live	Brown	Carries alternating potential difference from the supply.
Neutral	Blue	Completes the circuit.
Earth	Yellow/Green	Safety wire to stop appliance becoming live.

8. Explain why a live wire may be dangerous even when a switch in the mains circuit is open.

A person could complete the circuit to ground getting electrocuted.



**Power:** When electrical appliances are connected into a circuit **energy** is transferred to the appliance. The rate at which energy is transferred to the appliance is the **power** rating of the appliance.

To calculate the power of an electrical component:

Power (W)= Potential Difference (V) x Current (A)

$$P = V I$$

An alternative equation for calculating power is:

Power = (current)<sup>2</sup> x Resistance

$$P = I^2 R$$

Name	Equation symbol	Unit	Unit Symbol
Power	P	Watts	W
Potential difference	V	Volts	V
Current	I	Amp	A
Resistance	R	Ohms	Ω

# Power Equations

## Example

A microwave oven is powered by mains electricity at 230 V. The microwave oven has a power rating of 800 W.

Calculate the current flowing in the microwave oven.



**Solution:**

**State the equation:**  $P = VI$

**Rearrange:**  $I = P / V$

**Substitution:**  $I = 800 / 230$

**Answer:**  $I = 3.5 \text{ A}$  (to 1 decimal place)

# Power Equations... continued

Example:

An overhead powerline is 100 miles long and carries a current of 400 A. The powerline has a resistance of 27.5  $\Omega$ .

Calculate the power loss in the 100 mile length of powerline.



**Solution:**

**State the equation:**  $P = (I)^2 \times R$

**Substitution:**  $P = (400)^2 \times 27.5$

**Answer:**  $P = 4.4 \text{ MW}$  or 4 400 000 W

Therefore the power loss in the overhead powerline is 4.4 MW per 100 miles of cable.

# Energy Transfers in Everyday Appliances

Everyday electrical appliances are designed to bring about energy transfers.

The amount of energy an appliance transfers depends on how long the appliance is switched on for and the power of the appliance.

Electrical appliances convert electrical energy from ac mains, or from batteries into more useful forms.

Some common energy transfers from electrical energy include...

- **motors** converting electrical energy into kinetic energy
- **lightbulbs** converting electrical energy into light energy
- **electric heaters** converting electrical energy into heat energy.

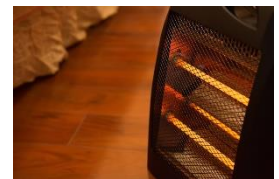

As with any energy transfer, some energy will be transferred **usefully** and some energy will be **wasted** (converted into forms that are not useful).

# Energy Transfers in Everyday Appliances

## Work Done in Electrical Circuits

Work is done when charge flows in a circuit.

The amount of energy transferred by electrical work can be calculated using the equation:

Energy transferred (J) = Power (W) × Time (s)

$$E = P t$$

Also: Energy transferred = Charge flow (C) × Potential difference (V)

$$E = Q V$$

Name	Equation symbol	Unit	Unit Symbol
Energy transferred	E	Joules	J
Power	P	Watts	W
Time	t	Seconds	s
Charge flow	Q	Coulombs	C
Potential difference	V	Volts	V



# Using Equations for Energy Transferred

Example:

An electric motor with a power rating of 5 kW is switched on for 2 minutes.

Work out the energy transferred by the electric motor.

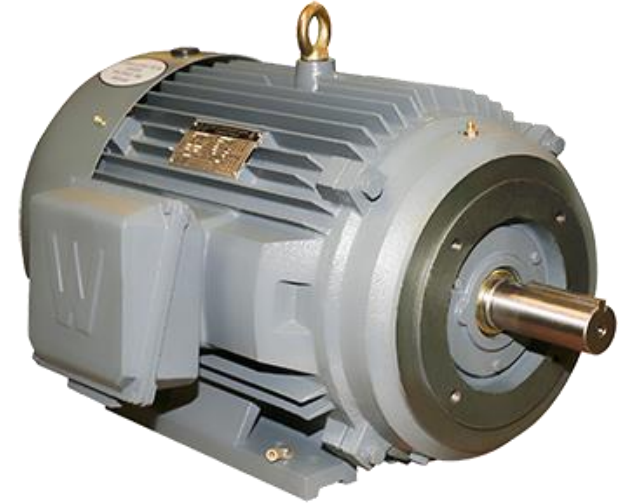

**Solution:**

Conversion into standard units: 5000 W for power and 120 s for time.

State the equation:

$$E = P t$$

Substitution:

$$E = 5000 \times 120$$

Answer:

$$E = \underline{600\,000 \text{ J or } 600 \text{ kJ}}$$

# Using Equations for Energy Transferred...continued

Example:

A different electric motor has a power rating of 8 kW. This electric motor runs off mains electricity at 230 V, 50 Hz ac.

Calculate the charge flow if this electric motor is left on for 1.5 minutes.

**Solution:**

*Conversion into standard units:* 8 kW = 8000 W and 1.5 minutes = 90 seconds

Calculate the energy transferred:

State the equation:

$$E = P t$$

Substitution:

$$E = 8000 \times 90$$

Answer:

$$E = 720\,000 \text{ J}$$

State the equation:

$$E = Q V$$

Rearrange:

$$Q = E/V$$

Substitution:

$$Q = 720\,000 / 230$$

Answer:

$$Q = \underline{3130 \text{ C}}$$

The National Grid is a system of cables and transformers linking power stations to consumers e.g. homes, shops, factories and.

Electrical power is transferred from power stations to consumers using:

## The National Grid

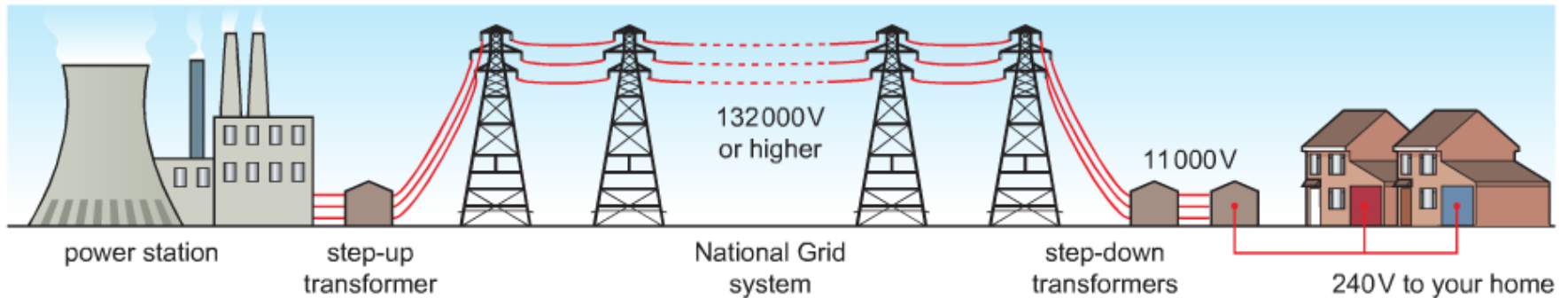

- **Step-up transformers** are used to **increase the potential difference** from the power station to the transmission cables.
- **Step-down transformers** are used to decrease, to a much lower value, the potential difference for domestic use in homes.

# Why are Transformers used in The National Grid?

Electric current **generates heat** as it **moves** through electrical wires.

If electricity is transmitted at a **very high potential difference** and low current this means less energy is **wasted** as heat making the whole system more efficient.

- **Step up** transformers – Increase the potential difference and decrease the current.
- **Step down** transformers - Decrease the potential difference and Increase the current.

A lower potential differences is used in the home as it is safer, so a step-down transformer is used near homes and offices.



Pylons carry overhead power cables

# QuestionIT!

## Energy Transfers

- Power
- Energy transfers in everyday appliances
- The National Grid



- 1. State the equation that links power, potential difference and current. Include equation symbols and units.**
- 2. State the equation that links power, current and resistance. Include equation symbols and units.**
- 3. Recall the two equations for energy transferred. Include equation symbols and units.**
- 4a) A kettle has a power rating of 1.2 kW.  
The kettle runs on mains electricity at 230 V.  
Calculate the current flowing through the kettle when in use.**
- 4b) The kettle takes 1 minute and 20 seconds to boil some water.  
Calculate the energy transferred by the kettle in this time.**
- 5. Describe fully how electricity is transmitted from power stations to our homes.**
- 6. Explain why a step-up transformer is used when transmitting electricity long distances across the UK.**

# AnswerIT!

## Energy Transfers

- Power
- Energy transfers in everyday appliances
- The National Grid



1. State the equation that links power, potential difference and current. Include equation symbols and units.
  - **Power = Potential Difference x Current**
  - **$P = V I$**
2. State the equation that links power, current and resistance. Include equation symbols and units.
  - **Power = (current)<sup>2</sup> x Resistance**
  - **$P = I^2 R$**

Name	Unit	Unit Symbol
Power	Watts	W
Potential difference	Volts	V
Current	Amp	A
Resistance	Ohms	$\Omega$



3. Recall the two equations for energy transferred. Include equation symbols and units.

- Energy transferred = Power × Time
- $E = P t$
  
- Energy transferred = Charge flow x Potential difference
- $E = Q V$

Name	Unit	Unit Symbol
Energy transferred	Joules	J
Power	Watts	W
Time	Seconds	s
Charge flow	Coulombs	C
Potential difference	Volts	V

4a) A kettle has a power rating of 1.2 kW.

The kettle runs on mains electricity at 230 V.

Work out the current flowing through the kettle when in use.

- 5.2 A
- $1.2 \text{ kW} = 1200 \text{ W}$
- $\text{Power} = \text{Potential difference} \times \text{Current}$
- $\text{Current} = \text{power} / \text{potential difference}$  or  $\text{current} = 1200 / 230$

4b) The kettle takes 1 minute and 20 seconds to boil some water.

Work out the energy transferred by the kettle in this time.

- 96 000 J
- $\text{Energy transferred} = \text{Power} \times \text{Time}$
- $\text{Energy transferred} = 1200 \times 80$

5. Describe fully how electricity is transmitted from power stations to our homes.
- A step-up transformer is used to increase potential difference / decrease current
  - Electricity transmitted along power cables (at high potential difference)
  - Step-down transformers used to decrease the potential difference before the electricity enters homes.
6. Explain why a step-up transformer is used when transmitting electricity long distances across the UK.
- Increasing the potential difference will decrease the current
  - Lower currents mean less heating of the power cables
  - So, less electrical energy wasted as heat
  - Making the transmission process more efficient.

This section is not for students who are doing combined Science.

# LearnIT! KnowIT!

## Static Electricity (Physics Only)

- Static charge
- Electric fields



# Static Charges

There are two types of **electrical charge**.

These are **positive (+)** and **negative (-)**.

When **two electrical charges** are placed near each other they exert a force on one another. The direction of the force depends on the electrical charges involved. **Electrostatic forces** are an example of non-contact forces.

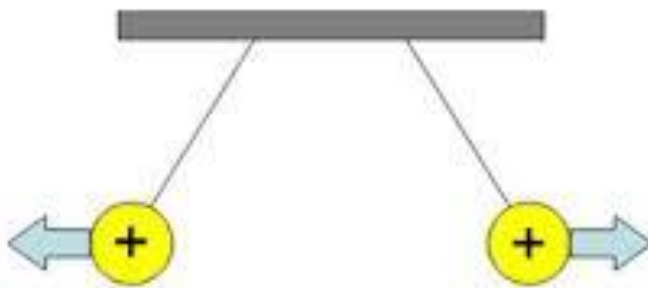

Likes repel

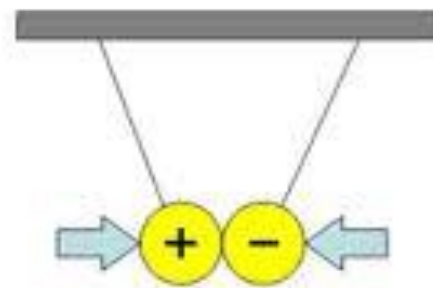

Opposites attract

## Producing a Static Charge

When certain insulating materials are rubbed against each other they become electrically charged. Negatively charged electrons are rubbed off one material and on to the other. The material that gains electrons becomes negatively charged. The material that loses electrons is left with an equal positive charge.

When you walk across a carpet in socks, the friction between the carpet and the socks can cause a build up of charge. This is noticeable when you touch something that is **earthed** afterwards and you get a small spark and an electric shock. The cause of the shock is electrons moving through you to ground.

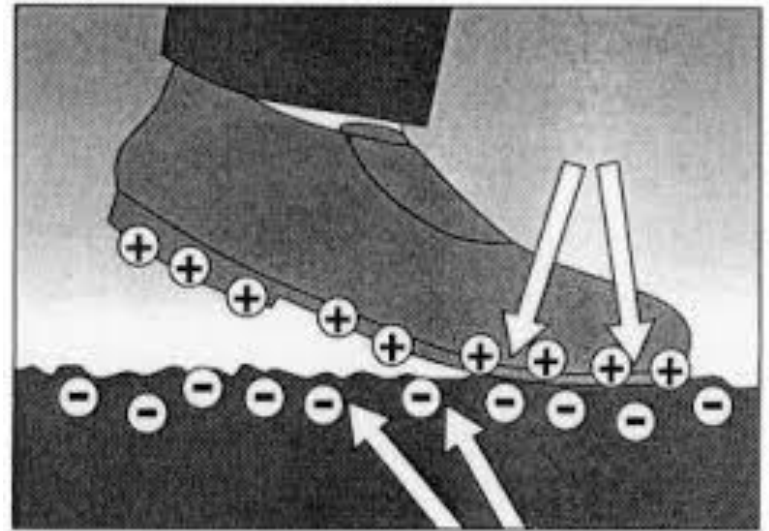

## Demonstration of Static

There are two common examples of static phenomena.

**Rubbing a balloon on your head:**

When you rub a balloon on your head **electrons are transferred**, causing a build up of **negative charge** on the balloon.

Placing a charged balloon over some dust will cause the dust to be attracted to the balloon.

Placing the charged balloon onto a wall can get the balloon to stick.



## Demonstration of Static

There are two common examples of static phenomena.

**Rubbing** a plastic rod, a comb for example, on some material will cause a **transfer of electrons**.

Placing the charged rod above bits of paper will get the paper to attract to the rod.

**The oppositely charged particles in the paper will be attracted to the rod.**

Placing the charged rod next to running water will get the water to attract towards the rod.





# Electric Fields

A charged object creates an electric field around itself. The electric field is strongest close to the charged object. The further away from the charged object, the weaker the field.

A second charged object placed in the field experiences a force. The force gets stronger as the distance between the objects decreases.

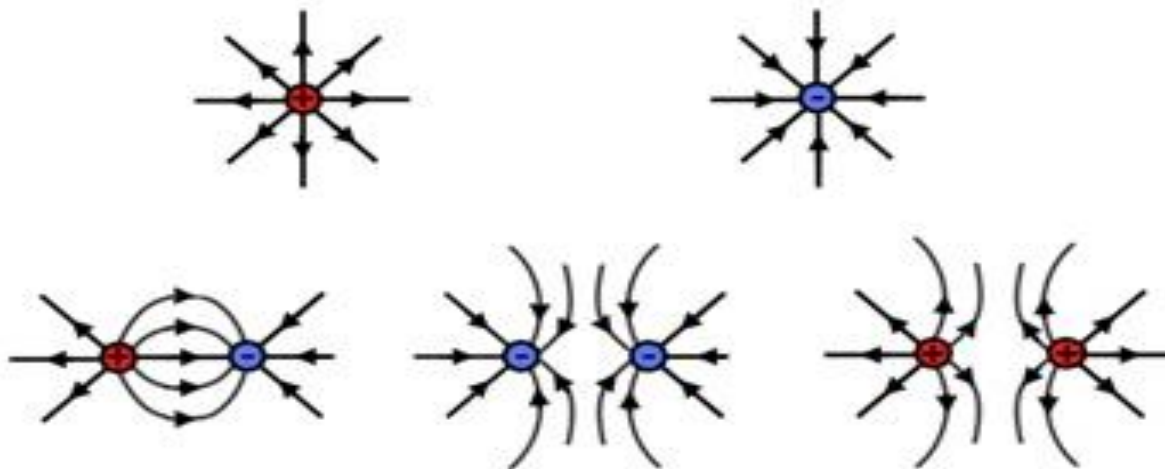

## Electric Field Patterns

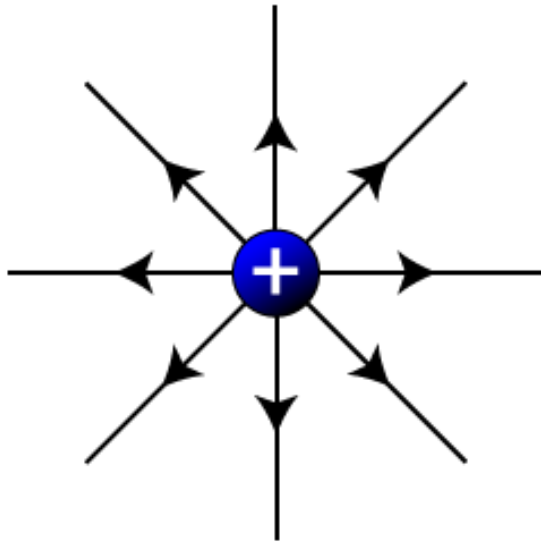

A positive isolated charge

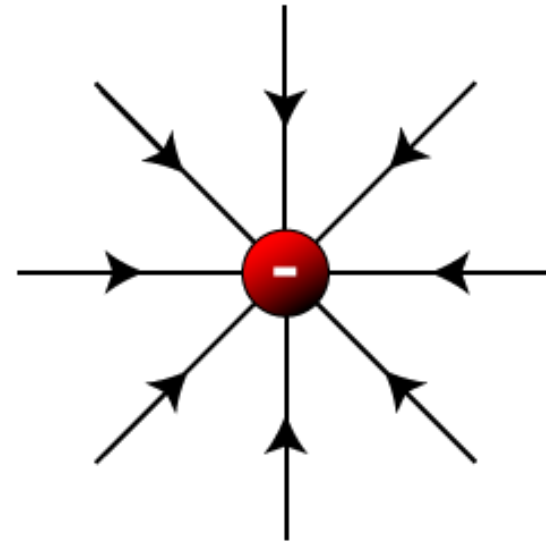

A negative isolated charge

**An electric field is the region around a charged particle within which a force would be exerted on another charged particle.**

## The Effects of an Electric Field

### Sparking:

When the **electric field strength** of a charged object is greater than the **dielectric field strength** a spark can occur. The dielectric field strength is the **maximum electric field strength** a material (usually air) can have without breaking down.

When the dielectric field strength is **exceeded** there is an **increase** in the number of **free electrons** in the air. This allows the air to conduct electricity and a spark is produced.



## The Effects of an Electric Field... continued

### Electrostatic Attraction:

When a **charged particle** is placed in an **electric field** the particle will experience a **force**.

The electric field acts like a force at a distance and the lines are considered the **lines of force**.

A **positively** charged particle placed in the electric field will move in the direction of the field lines. **Negatively** charged particles will move in the **opposite** direction.

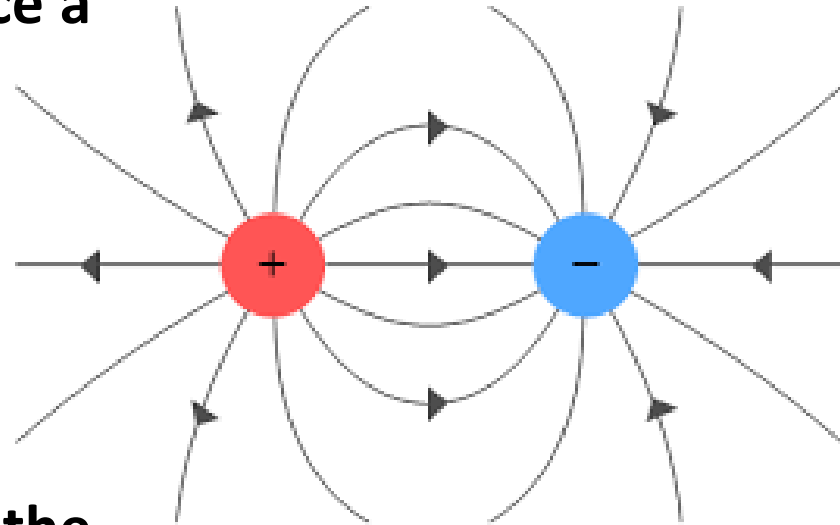

# QuestionIT!

## Static Electricity (Physics Only)

- Static charge
- Electric fields



- 1. Draw the electric field pattern of a positively charged particle.**
- 2. State the two types of electrical charge.**
- 3. Describe what would happen if two like charged particles were placed near each other.**
- 4. A balloon is rubbed on a jumper.  
The balloon becomes positively charged.  
Explain why the balloon gains a negative charge.**
- 5. Describe what would happen if a charged rod was placed above a pile of dust.**
- 6. What is an electric field?**
- 7. Mike gets off a trampoline and gets an electric shock. Mike sees a spark pass between himself and the trampoline.  
Explain why a spark formed in the air between Mike and the trampoline.**

# AnswerIT!

## Static Electricity (Physics Only)

- Static charge
- Electric fields



1. Draw the electric field pattern of a positively charged particle.

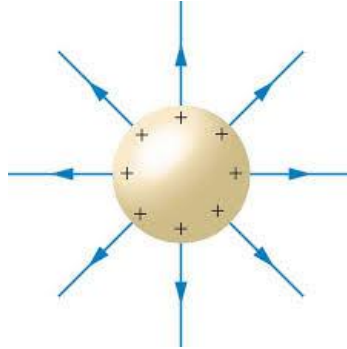

2. State the two types of electrical charge.
  - **Positive and negative**
3. Describe what would happen if two like charged particles were placed near each other.
  - **Two like charges would repel away from each other.**
4. A balloon is rubbed on a jumper.  
The balloon becomes positively charged.  
Explain why the balloon gains a negative charge.
  - **Electrons move from the jumper to the balloon**
  - **So there are more negative charges on the balloon than positive charges.**



5. Describe what would happen if a charged rod was placed above a pile of dust.
  - The dust will attract to the rod
  - Note: The dust will stick to the rod is not an acceptable answer.
6. What is an electric field?
  - An electric field is the space around a charged object that will exert a force upon another charged object that is placed there.
7. Mike gets off a trampoline and gets an electric shock. Mike sees a spark pass between himself and the trampoline.  
Explain why the spark formed in the air between Mike and the trampoline.
  - The electric field strength of Mike as a charged object
  - Is greater than the dielectric field strength of air
  - Causing an increase in the number of free electrons in the air
  - Allowing the air to conduct
  - And a spark to form.